

# Research on ecological environment impact assessment based on PSR and cloud theory in Dari county, source of the Yellow River

Wang Yongqiang, Wu Zhijun, Yan Bo, Li Kai and Huang Feng

## ABSTRACT

In order to reasonably evaluate the ecological environment of Dari County in the source region of the Yellow River, the characteristics and actual conditions of Dari County's ecological environment are taken into account, and the principles of representativeness, scientificity, operability and systematicness of index are followed. An evaluation index system is established for Dari County based on the Pressure-State-Response (PSR) conceptual framework. Combining the Analytic Hierarchy Process (AHP) with the cloud model, an ecological environment evaluation model for Dari County is established, and the ecological environment of Dari County is quantitatively evaluated. The model organically combines the ambiguity and randomness of the uncertainty concept. It not only describes the ambiguity of the evaluation level with a membership function, but also considers the randomness of the membership itself using the concept of superentropy, which is more in line with the actual evaluation object. The results indicate that the ecological situation of Dari County is in a 'general' state that should be urgently protected for sustainable development, and land degradation is the most important factor affecting the ecological environment of Dari County.

**Key words** | assessment, cloud model, Dari County, ecological environmental impact, PSR framework

**Wang Yongqiang**

**Wu Zhijun**

**Yan Bo** (corresponding author)

**Li Kai**

Water Resources Department (International River Management Department),  
Changjiang River Scientific Research Institute,  
Wuhan 430010,  
China

and

Hubei Provincial Key Laboratory of Basin Water Resources and Ecological Environmental Sciences,

Changjiang River Scientific Research Institute,  
Wuhan 430010,  
China

E-mail: [byanhhu@163.com](mailto:byanhhu@163.com)

**Wu Zhijun**

**Huang Feng**

College of Hydrology and Water Resources,  
Hohai University,  
Nanjing 210098,  
China

## HIGHLIGHTS

- A model method combining AHP and cloud model.
- The ecological environment of Dari County is in a general state.
- The evaluation index system of Dari County based on PSR framework is proposed.
- Land degradation is an important factor affecting the ecology of Dari County.
- The evaluation model can take into account both ambiguity and randomness.

## INTRODUCTION

The source region of the Yellow River is located in southwest Qinghai Province, the hinterland of the Qinghai-Tibet Plateau. It is an important water conservation area and ecological barrier of the Yellow River, as well as one of the

most special and fragile areas in China. With the influence of climate change and human activity, the ecological environment in parts of the source Yellow River areas have suffered damage in recent years. To protect the ecological environment, it is necessary to know and quantitatively evaluate the current state of the regional ecological environment. The difficulty is how to select the corresponding evaluation index system according to the regional characteristics and

This is an Open Access article distributed under the terms of the Creative Commons Attribution Licence (CC BY 4.0), which permits copying, adaptation and redistribution, provided the original work is properly cited (<http://creativecommons.org/licenses/by/4.0/>).

doi: 10.2166/ws.2020.286

make a reasonable quantitative analysis. In view of this, assessing the state of the ecological environment in the river source area is of great significance for its protection and restoration. This paper selects the 'Pressure-State-Response (PSR)' model as the index system construction model. At present, domestic research scholars have widely used this model in the fields of water environment safety assessment, urban planning environmental impact assessment, and wetland ecosystem health assessment. For example, Li Lin's study on the evaluation of urban lake water environment safety divides the evaluation indicators of urban lake water environment safety into three levels: pressure-state-response. The pressure layer selects the most threatening indicators for lake water environment safety, and the state layer selects the representative lake State indicators, the response layer selects indicators that reflect the measures taken in lake management. Xu Youpeng's wetland ecological health assessment based on the 'stress-state-response' model and fractal theory: stress reflects the impact and stress of human activities on the wetland ecosystem, reflects the intensity and change trend of resource utilization; state reflects the wetland ecological environment, the change of elements reflects the ultimate goal of the environmental protection policy; the response reflects the measures taken by the society or individuals to stop, mitigate, prevent or restore the changes of the wetland ecosystem. The PSR model framework provides an evaluation idea, emphasizing the causal logic of the ecological environment impact process, and the need to analyze the change process of the evaluation object. The model is simple and easy to use and is widely used. Foreign scholars have applied the PSR model to environmental sustainability, regional sustainable development, and ecological security Lin Zhen's (Zhen *et al.* 2009) Comparison of sustainability issues in two sensitive areas of China uses the PSR model to select the indicators of two sensitive agricultural areas in China to assess the sustainability of the two areas. Yang Pei's (Yang *et al.* 2011) Ecological Risk Assessment of the Shenzhen River-Bay Watershed builds a pressure-effect-social response (PESR) ecological risk Evaluation System. The fuzzy comprehensive evaluation method (FCE) is used to calculate the risk index of each subsystem. At present, selection of specific indicators for ecological environment evaluation needs to consider different regional

characteristics. For example, He Sanwei (Sanwei *et al.* 2011) reflects the ecological environment of agricultural land from the three aspects of water, soil, and climate based on PSR and cloud theory, considering fertilizer, irrigation condition and the degree of mechanization, and then a PSR-based agricultural land ecological environment evaluation index system is constructed. Zhang Zezhong (Zezhong *et al.* 2014) comprehensively assesses the current status and changes of ecological impacts of the North Canal from the perspective of river hydrological conditions, water environmental conditions, habitat quality and biological conditions. Compared with the ecological environment studies on watershed and agricultural land, there are fewer on the source region of the Yellow River (Zhongzheng *et al.* 2003). Wei Jing's evaluation of the ecological environment vulnerability in the Three Rivers source area (Jing *et al.* 2015) selects meteorological factors, topographic factors, surface factors, vegetation net primary productivity (NPP), vegetation coverage factors and indicators of human and economic activities for comprehensive evaluation based on the definition of ecological environment vulnerability and ecological sensitivity-ecological resilience-ecological pressure (SRP) model. Wu Qing (Qing & Yanli 2002) systematically analysed the causes of water resources fragility in the source Yellow River region, such as the uneven spatial and temporal distribution of climate and rainfall, grassland degradation, land desertification, and human activities, and its ecological impacts. Based on the latest research results, this paper attempts to put forward the PSR framework eco-environmental impact assessment index system in Dari County, the source region of the Yellow River.

In the existing researches, the domestic ecological environment assessment of river basins, plateau regions or eco-environment impacts of projects are mainly focused at home, while ecological impact assessments from certain perspective are concerned abroad (Bartsev *et al.* 2012; Carlos *et al.* 2020). But so far, related to regional ecological environment impact assessment, models are not clear and methods are close at home and abroad. The evaluation methods are mostly fuzzy comprehensive methods (Jun *et al.* 2013), Back Propagation (BP) neural network method, system dynamics (Hjorth & Bagheri 2005) and other related methods. The BP neural network method results in problems of inconsistency in the actual process.

The fuzzy comprehensive method divides the fuzzy classification boundary of indexes, but the calculated membership degree is easily disturbed by subjective conditions. The system dynamics method is to build a model around the problem; results will vary greatly because of different models for same problem. In summary, the existing quantitative evaluation methods and models can obtain regional ecological environment impact level, but cannot explain the level conversion status, because they ignored the ambiguity of the quantitative index description and the randomness of the index value determination and rating division. Academician Li (1998) first proposed the cloud model, which can take both ambiguity and randomness of evaluation into account, and has been widely used in multi-attribute decision-making, analysis and evaluation. For example, Zhang Yang's (Yang *et al.* 2013) assessment of land resource ecological security in Hubei Province is based on the normal cloud model. This study introduces the normal cloud model into the assessment of regional land resource ecological security. Taking Hubei Province as an example, a quantitative measurement of the regional land resource ecological security status is made. In Gao Mingmei's (Mingmei *et al.* 2015) application of the normal cloud model in the evaluation of land ecological security in Wanjiang area, the concept portrays the randomness of the membership degree itself, and obtains the land ecological security level of Wanjiang area.

The source region of the Yellow River studied in this paper has the characteristics of ecological fragility and has ambiguity and randomness from the perspective of mathematical theory. Therefore, we introduce the PSR indicator system framework and cloud model theory. The 'Pressure-State-Response' evaluation model is different from the traditional ecological evaluation framework. Organizing and classifying ecological indicators based on the interaction and impact of the ecosystem has a strong systematic and distinct ecological significance. The cloud model is used to convert between qualitative concepts and quantitative values, and is an important method in the evaluation of uncertain artificial intelligence. In this paper, Dari County, which is in the source region of the Yellow River, is taken as the study area. Considering its local ecological environment characteristics and actual conditions, and following the principles of indicator system construction such as representativeness, scientificity, operability, and systematicness,

the 'Pressure-State-Response' indicator conceptual model is established. Based on the actual conditions of the Yellow River source which is a water conservation ecological function area, the ecological environment impact indicator system of Dari County was constructed, and the orderly levels of each indicator in the evaluation target and the objective judgment of expert opinions were analyzed by the analytic hierarchy process (Ying *et al.* 2007). Combine them effectively and use mathematical methods to determine weights. Then the cloud model is used to quantitatively evaluate the ecological environment impact of Dari County, for objectively giving its environment status.

## STUDY AREA AND DATA SOURCE

### Study area

Dari County is located in the Sanjiangyuan District (Figure 1). The source area of the river is located in the southwest of Qinghai Province in the hinterland of the Qinghai-Tibet Plateau and is the source of the Yangtze, Yellow and Lancang Rivers. It is an ecological barrier for the ecological environment and regional sustainable development of the middle and lower reaches of China's rivers and Southeast Asian countries. Dari County is the core area of the Sanjiangyuan, and its ecological location is very important. It is of great significance for ensuring the safety of the ecological environment of the Sanjiangyuan and promoting the development of the regional ecological environment (He *et al.* 2018). In recent years, regional climate change and intensified human activities have caused a decrease in precipitation, which has reduced water conservation functions, reduced water production, and reduced forest and grass coverage. Regional socio-economic development has had a serious impact (details in Table 1).

### Data source

The basic data used in this paper is collected from China National Data Network (<http://data.stats.gov.cn/>), Chinese Academy of Sciences Resource and Environmental Science Data Center (<http://www.resdc.cn/>), Qinghai Meteorological Bureau Climate Data Center, field survey, annual statistics of various indicators.

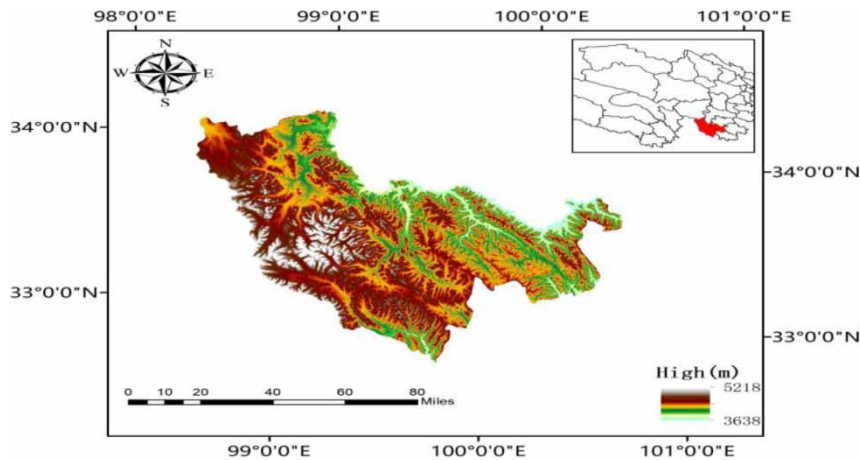

**Figure 1** | Geographical location of the research area in Dari County, Qinghai Province.

**Table 1** | Characteristics of ecological and environmental in Dari County

Name	Data	Name	Data
Annual rainfall	570 mm	Aridity index	1.96
Annual average temperature	-1.3 °C	Natural grassland area	$140 \times 10^4 \text{hm}^2$
Annual evaporation	1,120 mm	Utilizable grassland area	$111 \times 10^4 \text{hm}^2$
Wind speed	34 m/s	Deteriorated grassland area	$78 \times 10^4 \text{hm}^2$
Total land area	$148 \times 10^4 \text{hm}^2$	'Black Soil Type' deteriorated grassland area	$57 \times 10^4 \text{hm}^2$

## REGIONAL ECOLOGICAL EVALUATION INDEX SYSTEM BASED ON PSR

### PSR

The PSR model is an indicator selection framework based on the interconnections between indicators. It grasps the development process of the ecological environment impact by analyzing status changes. According to the environment of different areas, the corresponding indicators are selected to constitute the index layer, so as to focus on the ecological environment of Dari County. Then, an ecological environment impact assessment index system based on PSR and a target framework suitable for Dari County were constructed.

According to the PSR model framework, pressure index refers to the interference and pressure factors from external conditions in the evaluation index system constructed, state index is used to reflect the ecological environment, and the response category refers to the impact of the ecosystem

under the current ecological environment pressure (Long et al. 2012). Interconnect the three aspects of pressure-state-response to build the framework of the ecological environment impact assessment system, and select specific indicators to form a three-level indicator system.

### Evaluation index system for Dari County

The construction of an assessment index system is the basis for conducting an ecological environment impact assessment. But considering that different regions have different characteristics, a specific research indicator system and evaluation model need to be carried out for the study area, based on its ecological environment characteristics and actual conditions. Details of the eco-environmental impact assessment index system of Dari County are in Table 2. Apart from the influence of water resources, mainly climate factors, grassland degradation and land desertification are major factors that cause ecological and environmental

**Table 2** | Index system of ecological environment impact assessment in Dari County

Target layer	Criterion layer	Indicator layer	Indicator meaning
Ecological Environmental Impact Assessment	Pressure	Annual precipitation P1	The impact of rainfall on vegetation growth
		Drying index P2	The pressure of climate dryness
	State	Grass coverage S1	Represents a green sustainable state, the foundation for water renewal
		Soil salinity S2	Indicates the local soil salinity status
		Soil water content S3	State of soil water storage capacity
	Response	Soil erosion area ratio R1	Response to grassland degradation
		Land degradation rate R2	Response to the formation of 'black soil beach'
Soil erosion modulus R3		Responds to soil holding capacity	

impacts in Dari County. In the construction of the index system, the climate and the degree of dryness reflect the disturbance and pressure factors of the water resources, which is an important factor in environmental changes. The state of soil salinity, soil moisture content, and grassland coverage are selected to reflect the ecological environment condition of Dari County. Degradation of grassland weakened the regulation of vegetation on land runoff. The response of the ecological environment refers to the impact of the ecosystem under the current ecological environment pressure, which is mainly represented by soil erosion and land degradation.

### Grading standards

There are regional differences in the standards of the ecological environment index levels. This study takes into account the actual situation of Dari County in the source region of the Yellow River, with reference to the research results of ecological index thresholds at home and abroad, ecological environment evaluation standards, standards issued by

local governments, and planning objectives, etc. (Jinrui et al. 2003; Jian et al. 2006) The eco-environment evaluation level of Dari County in the source region of the Yellow River is divided into four levels: poor, fair, good and excellent. Finally, combined with the opinions of experts, the classification standards for regional ecological environment evaluation indicators are obtained. The specific ecological environment classification standards are shown in Table 3.

## CLOUD MODEL EVALUATION METHOD

### Cloud model

The cloud model (Lujun & Yaping 2000) is an uncertainty model proposed by Academician Li Deyi that can be used to represent both a certain qualitative concept and its quantitative concept. It shows an advantage in the analysis of the randomness and ambiguity of the thing itself for unified analysis. The model is a new mathematical model, which is characterized by a combination of normal distribution and

**Table 3** | Classification standard for ecological environment impact assessment in Dari County

Target layer	Criterion layer	Indicator layer	Evaluation standard			
			I (Poor)	II (General)	III (Good)	IV (Better)
Ecological Environment Impact Assessment	Pressure	Annual precipitation P1	<1,000	1,000–1,300	1,300–1,500	>1,500
		Drying index P2	>4	4.0–1.2	1.2–1	<1
	State	Grass coverage S1	<15	15–20	20–25	>25
		Soil salinity S2	>5	3–5	2–3	<2
		Soil water content S3	<5	5–12	12–15	15–20
	Response	Soil erosion area ratio R1	>35	20–35	5–20	<5
		Land degradation rate R2	>10	6–10	4–6	<4
Soil erosion modulus R3		>5,000	2,500–5,000	1,000–2,500	<1,000	

membership function and has a wide range of universality. The three digital characteristics of the cloud model are expected value ( $Ex$ ), entropy ( $En$ ), and superentropy ( $He$ ) (Yang et al. 2013).  $Ex$  represents the grade point value of the ecological environment impact assessment of Dari County, while  $En$  divides the index level. The degree of uncertainty and dispersion of each index is expressed by  $He$ , which indicates the degree of correlation between randomness and ambiguity within indicators. The three characteristic value parameters ( $Ex, En, He$ ) of each grade cloud are determined by the upper and lower boundary values of each grade of the evaluation index corresponding to the grade, which can be obtained by the corresponding characteristic value parameter value formula. There is data  $x_{ij}$ , where  $i$  is the evaluation index, and  $j$  is the evaluation level corresponding to the data  $x$ ; then there are  $x_{ij}^1$  and  $x_{ij}^2$  for the upper and lower boundary of the data  $x_{ij}$ . Model representation can obtain an  $i * j$  cloud model. Since the intermediate value of each level is the qualitative concept that can best represent that level, the expected value is expressed as:

$$Ex_{ij} = \frac{(x_{ij}^1 + x_{ij}^2)}{2} \tag{1}$$

As the boundary of each level,  $x_{ij}$  belongs to both the previous level and the next level, so the boundary value is equal to the membership degree of the upper and lower levels, thereby obtaining the entropy value:

$$En_{ij} = \frac{(x_{ij}^1 - x_{ij}^2)}{6} \tag{2}$$

The size of  $He$  is generally obtained based on the entropy value and experience, which mainly reflects the thickness of the cloud layer, which is 0.01 here:

$$He = T \tag{3}$$

**Ecological environment impact assessment model based on cloud model**

In the process of quantitatively measuring the regional ecological environment, the quantitative description of its evaluation indicators has both ambiguity and randomness. If only the ambiguity or randomness of the objects in the

regional ecological environment evaluation is considered, then an accurate evaluation result is expected. The purpose is difficult to achieve, so it is necessary to introduce a model method that can take into account both ambiguity and randomness. This study builds on the normal cloud model theory and builds a comprehensive evaluation model based on the normal cloud. The construction of the evaluation model is mainly divided into the following parts: (Figure 2).

- Establish an index system ( $X1, X2, X3, \dots, Xn$ ) of the ecological environment impact assessment, and formulate an evaluation level standard  $V = \{V1, V2, \dots, Vm\}$ .
- Evaluate each index in the system and establish a fuzzy matrix  $R$ . The element  $r_{ij}$  in  $R$  represents the degree of membership of the  $i$ -th element in the system.

$$r_{ij} = (Ex_{ij}, En_{ij}, He), \quad R = \begin{pmatrix} r_{11} & \dots & r_{1j} \\ \vdots & \ddots & \vdots \\ r_{i1} & \dots & r_{ij} \end{pmatrix}$$

- Take the quantitative value  $r_{ij}$  of each index as the input for the cloud generator to get a set of cloud drops ( $a, y$ ). Execute the cloud generator multiple times, and determine the cloud membership matrix  $Z = (Z_{ij})_{n * m}$ . Cloud generator algorithm: First set  $Ex$  as the expected value and  $He$  as the standard deviation to generate a

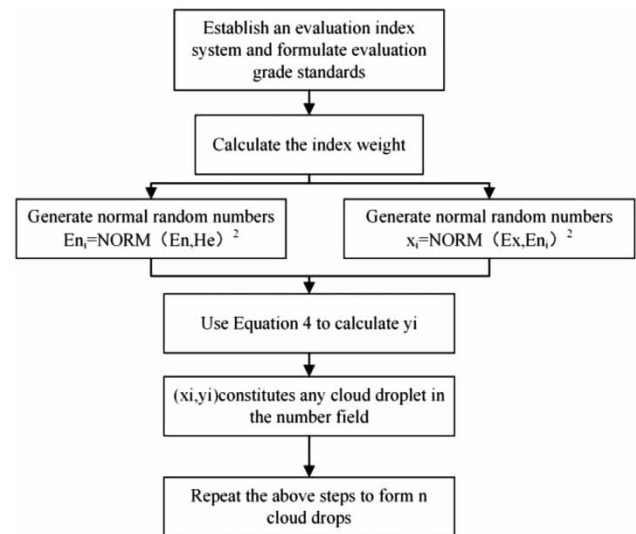

Figure 2 | Cloud model calculation flow chart.

normal random number  $En'$ , and then set  $Ex$  as the expected value and  $En'$  as the standard deviation to generate a normal random number  $a$ . After the degree of certainty is calculated by using the (Equation (4))  $N$  cloud droplets are generated by repeating  $N$  times. The calculation principle is shown in Figure 3.

$$y = \exp \left\{ - \frac{(x - Ex)^2}{2En'^2} \right\} \tag{4}$$

### Determination of indicator weights

In the process of regional eco-environmental assessment, the degree of influence of different evaluation factors on the evaluation results is different. Therefore, it is first necessary to determine the degree of influence (weight) of each evaluation factor on the evaluation results. Hierarchical analysis method (AHP) is used to determine the weight of each evaluation index in the ecological environment evaluation index system. According to the steps of the analytic hierarchy process, first construct a hierarchical hierarchy structure, namely the target layer, the criterion layer and the factor layer of the evaluation index system, and then compare the two elements in turn to construct a judgment matrix, and then calculate the relative weights, and then make it consistent. The test is terminated after passing the test. (Changyu et al. 2005).

After the largest eigenvalue  $\lambda$  and the eigenvector  $\bar{w}$  are calculated by the sum-product method, the weights of each index are acquired. And then a consistency check for each

index is conducted. If the judgment matrix meets check, the calculated weight is available for use. The calculation steps are as follows:

- Normalize the vector

$$\bar{w}_{ij} = \frac{a_{ij}}{\sum_{i=1}^n a_{ij}}, j = 1, 2, 3, \dots, n \tag{5}$$

- Sum  $\bar{w}_{ij}$

$$\bar{w}_{ij} = \sum_{j=1}^n \bar{w}_{ij}, i = 1, 2, \dots, n \tag{6}$$

- Normalize  $\bar{w}_{ij}$

$$w_i = \frac{\bar{w}_i}{\sum_{i=1}^n \bar{w}_i} \tag{7}$$

- Calculate the largest eigenvalue  $\lambda$

$$\lambda = \frac{1}{n} \sum_{i=1}^n \left[ \frac{(Aw)_i}{w_i} \right] \tag{8}$$

- Perform consistency check

$$CI = \frac{(\lambda - n)}{(n - 1)} \tag{9}$$

$$CR = \frac{CI}{RI} \tag{10}$$

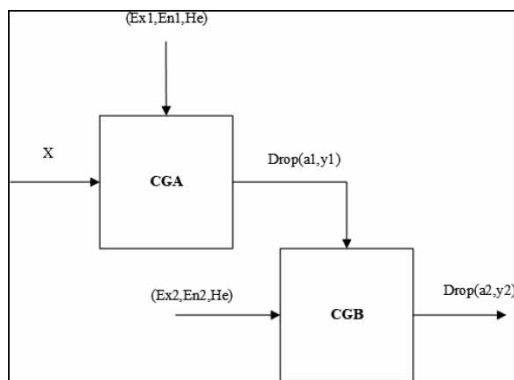

Figure 3 | Cloud generator.

### Evaluation process

The AHP method is a combination of qualitative and quantitative methods for seeking weights. It can test and reduce the influence of subjective factors, making the analysis and evaluation more objective and scientific. At the same time, the cloud model can reduce the impact of ambiguity and randomness in the evaluation process. Coupling the AHP method with the cloud model can take advantage of the two and apply it to the evaluation of uncertain systems. The evaluation process is as follows.

Select suitable indicators for the target layer and set evaluation level standards for each indicator. Use the AHP method to acquire the weight of each indicator. After calculating the degree of certainty with the help of the three digital features by cloud model, each object is evaluated by getting the indicator value. And a membership matrix is obtained by using the cloud generator. When calculating the membership of each level, the level corresponding to the maximum membership is selected as the comprehensive evaluation result of the object to be evaluated (Figure 4).

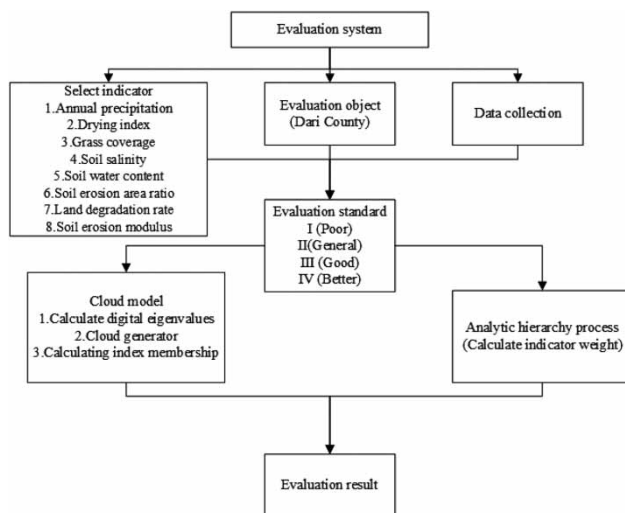

Figure 4 | Evaluation flowchart.

## RESULTS AND DISCUSSION

This section introduces the calculation process of eco-environmental impact assessment based on the data of Dari County. Use the three digital feature expected values ( $Ex$ ), entropy ( $En$ ), and superentropy ( $He$ ) of the normal cloud model to characterize the qualitative concepts of each index. According to Equations (1)–(3), the corresponding range of levels of each index in Table 2 is represented as a normal cloud, as shown in Table 4.

According to the evaluation standards of each index, the forward cloud generator model is used to obtain the standard normal cloud model parameters of each index by calculating  $Ex$ ,  $En$ , and  $He$  of each index corresponding to different evaluation levels (Table 5). Then  $N$  ( $N = 1,000$ ) cloud droplets are generated, and the normal membership cloud maps of each evaluation index are obtained. The abscissa represents the actual value of grassland coverage, and the ordinate represents the degree of correlation corresponding to each security level. A certain degree of association may correspond to different index values, which reflects the fuzzy uncertainty between the index value and the level to be determined (Figure 5).

The cloud certainty of each index is calculated through forward cloud generator to form a membership matrix based on the preliminary calculating results, as shown in Table 6.

The weight of each index in the ecological environment impact assessment is calculated by the above-mentioned

Table 4 | Grading standards of evaluation indexes in Dari County

Evaluation index	Evaluation standard			
	I (Poor)	II (General)	III (Good)	IV (Better)
P1	(750, 83.3, 0.01)	(1, 150, 50, 0.01)	(1, 400, 33.3, 0.01)	(1, 750, 83.3, 0.01)
P2	(5, 0.33, 0.01)	(2.6, 0.46, 0.01)	(1.1, 0.03, 0.01)	(0.5, 0.16, 0.01)
S1	(7.5, 2.5, 0.01)	(17.5, 0.83, 0.01)	(22.5, 0.83, 0.01)	(27.5, 0.83, 0.01)
S2	(6, 0.33, 0.01)	(4, 0.33, 0.01)	(2.5, 0.16, 0.01)	(1, 0.33, 0.01)
S3	(2.5, 0.83, 0.01)	(8.5, 1.17, 0.01)	(13.5, 0.5, 0.01)	(17.5, 0.83, 0.01)
R1	(42.5, 2.5, 0.01)	(27.5, 2.5, 0.01)	(12.5, 2.5, 0.01)	(2.5, 0.83, 0.01)
R2	(12.5, 0.83, 0.01)	(8, 0.67, 0.01)	(5, 0.33, 0.01)	(2, 0.67, 0.01)
R3	(5, 500, 166.67, 0.01)	(3, 750, 416.67, 0.01)	(1, 750, 250, 0.01)	(500, 166.67, 0.01)



**Table 5** | Scale and meaning

Scale level	Relative importance judgment
1	X1 is just as important as X2
3	X1 is more important than X2
5	X1 is significantly more important than X2
7	X1 is much more important than X2
9	X1 is most important than X2
2,4,6,8	Between adjacent odd numbers

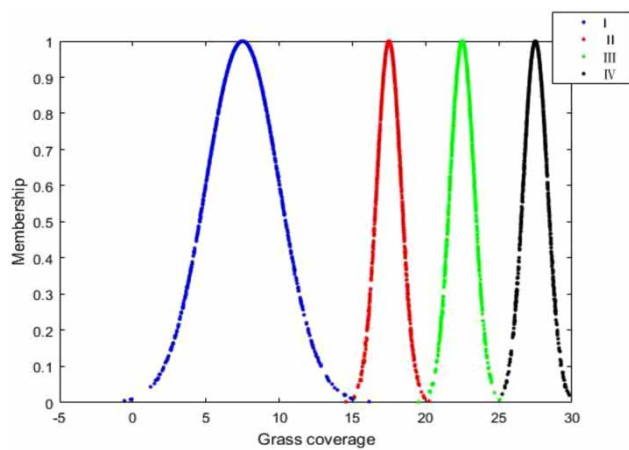

**Figure 5** | Cloud model of grassland coverage in Dari County.

**Table 6** | Membership of the evaluation index cloud model in Dari County

Evaluation index	Membership			
	I (Poor)	II (General)	III (Good)	IV (Better)
P1	0.09	0	0	0
P2	0	0.36	0	0
S1	0	0	0	0.12
S2	0	0.16	0	0
S3	0	0.69	0	0
R1	0	0.84	0	0
R2	0.43	0	0	0
R3	0	0.54	0	0

AHP method. The result is  $W = [0.1178, 0.0393, 0.0797, 0.1392, 0.0304, 0.0696, 0.3647, 0.1591]$ .

The relationship of comprehensive membership (B), which reflects the ecological environment assessment level

**Table 7** | Membership degree of evaluation index in normal cloud model in Dari County

Area	Evaluation standard				Grade
	I (Poor)	II (General)	III (Good)	IV (Better)	
Dari County	0.17	0.2	0	0	II级

of Dari County, index weight (W) and index membership (R) is shown as Equation (11).

$$B = W \times R \tag{11}$$

The four levels' comprehensive membership of ecological environment assessment in Dari County is calculated based on the formula. According to the maximum value determination method, the evaluation level belongs to 'general' (Table 7). Although the ecological environment of Dari County has been in a 'general' state, land desertification, which is one of the most serious ecological and environmental problems, cannot be underestimated. The assessment result of Dari County carried by cloud model is basically consistent with actual conditions, indicating that the assessment model has certain rationality and reliability.

## CONCLUSIONS

This paper evaluates the ecological and environmental impacts in Dari County. The evaluation results intuitively reflect the ecological environment. The following conclusions are mainly drawn.

- As can be seen in the evaluation results, the ecological environment in Dari County is in a 'general' state. It urgently needs to be improved to reach a sustainable development state.
- As can be seen in the PSR index system, the land degradation rate in Dari County is particularly serious. In future work, the prevention of 'black soil beach' and the improvement of vegetation coverage, such as forest rate, in Dari County should be paid more attention, the problems of soil erosion, land salinization should be concerned, and the pressure on the local ecosystem due to human activities should be effectively controlled.

Problems in ecological environment affect many aspects such as water resources and human activities, and the characteristics of the ecological environment are quite different in different regions. Therefore, no unified understanding of ecological environment impact assessment is accepted by scholars at home and abroad. This paper analyzes the ecological environment characteristics and actual conditions of Dari County, which is in the source region of the Yellow River, constructs an evaluation system based on the PSR concept framework and builds an ecological environment impact assessment model based on the cloud model. The results provide a preparation for further study on the ecological environment of the source Yellow River region. However, there are also some deficiencies in this paper. The ecological and hydrological impact on the local ecological environment is mainly considered in this paper, and the impact of human activities, such as rodent harm, overgrazing, and other factors have not been discussed in the evaluation system.

## ACKNOWLEDGEMENTS

This work is funded by the National Key R&D Program of China (2017YFC0403600, 2017YFC0403606), the National Natural Science Foundation of China (No.51779013,51639005), National Public Research Institutes for Basic R&D Operating Expenses Special Project (No.CKSF2019478, No.CKSF2017061). Special thanks are given to the anonymous reviewers and editors for their constructive comments.

## DATA AVAILABILITY STATEMENT

All relevant data are included in the paper or its Supplementary Information.

## REFERENCES

Bartsev, S. I., Degermendzhi, A. G., Okhonin, V. A. & Saltykov, M. Y. 2012 An integrated approach to the assessment of an

- ecological impact of industrial products and processes. *Procedia Environmental Sciences* **13**, 837–846.
- Carlos, C., Rubén, V., Breixo, M.-R. & Alejo, C. 2020 The cotton-strip assay as an environmental surveillance tool for ecological integrity assessment of rivers affected by WWTP effluents. *Water Research* **169**, 115247.
- Changyu, L., Deyi, L., Yan, D. & Xu, H. 2005 Statistical analysis of normal cloud model. *Information and Control* **02**, 236–239. + 248.
- He, W., Zhanxiu, Z. & Xiaoyong, W. 2018 Analysis on the trend and cycle of temperature change in Dari county from 1956 to 2015. *Modern Agricultural Science and Technology* **18**, 214–215.
- Hjorth, P. & Bagheri, A. 2005 Navigating towards sustainable development: a system dynamics approach. *Futures* **38** (1), 74–92.
- Jian, S., Yuhua, L., Jianglan, S., Gaihe, Y. & Dexiang, W. 2006 Comprehensive evaluation of the ecological environment quality in the source area of the river. *Journal of Northwest A & F University (Natural Science Edition)* **6** (10), 61–66.
- Jing, W., Yamin, G., Lin, S., Tao, J., Xinpeng, T. & Guangde, S. 2015 Evaluation of ecological environment vulnerability in three river source regions. *Chinese Journal of Ecology* **34** (07), 1968–1975.
- Jinrui, Y., Yang, F. & Fengxia, L. 2003 Research on the ecological environment division and quality evaluation index system of Qinghai Province. *Qinghai Meteorology* **7** (01), 34–40.
- Jun, Y., Zhanqi, W., Gui, J., Bingyin, C. & Xianhui, H. 2013 Evaluation of post-implementation benefit of land improvement projects based on AHP and fuzzy comprehensive evaluation. *Resources and Environment in the Yangtze River Basin* **22** (08), 1036–1042.
- Li, D. 1998 Uncertainty reasoning based on cloud models in controllers. *Computers and Mathematics with Applications* **35** (3), 99–123.
- Long, Y., Kelong, C., Shuangcheng, L., Shengkui, C. & Yanpeng, W. 2012 Relationships between soil physical and chemical properties, species diversity, and aboveground biomass of alpine meadows in Dari county. *Territory & Natural Resources Study* **03**, 92–94.
- Lujun, L. & Yaping, Y. 2000 Research on the evaluation methods of county ecological environment quality. *Environmental Monitoring Management and Technology* **04**, 13–17.
- Mingmei, G., Tao, S., Tianyan, Z., Hongjun, D. & Kun, Z. 2015 Application of normal cloud model in evaluation of land ecological security in Wanjiang area. *Journal of Hunan Agricultural University (Natural Science Edition)* **41** (02), 196–201.
- Qing, W. & Yanli, Z. 2002 Analysis of ecological environment changes and water resources vulnerability in the source regions of the Yellow River. *Water Resources Protection* **04**, 21–24.
- Sanwei, H., Peng, P., Haijun, W. & Lian, Y. 2011 Eco-environment evaluation of agricultural land based on PSR and cloud theory: a case study of Xinxing County,

- Guangdong Province. *Journal of Natural Resources* **26** (08), 1346–1352.
- Yang, P., Mao, X., Li, T. & Gao, X. 2011 [Ecological risk assessment of the Shenzhen River-Bay Watershed](#). *Human and Ecological Risk Assessment* **17** (3), 580–597.
- Yang, Z., Jinming, Y., Ping, J. & Nai, Y. 2013 Evaluation of ecological security of land resources in Hubei province based on normal cloud model. *Transactions of the Chinese Society of Agricultural Engineering* **29** (22), 252–258.
- Ying, X., Zeng, G.-M., Chen, G.-Q., Tang, L., Wang, K.-L. & Huang, D.-Y. 2007 Combining AHP with GIS in synthetic evaluation of eco-environment quality – a case study of Hunan Province, China. *Ecological Modelling* **209** (2), 97–109.
- Zezhong, Z., Qingqing, Q., Yun, G., Gangfu, S., Xiaonan, C. & Xin, W. 2014 Comprehensive evaluation of river ecological impact based on cloud theory. *Journal of North China University of Water Resources and Hydropower (Natural Science)* **35** (02), 30–34.
- Zhen, L., Cao, S., Wei, Y., Dilly, O., Liu, X., Li, F., Koenig, H., Tscherning, K. & Helming, K. 2009 [Comparison of sustainability issues in two sensitive areas of China](#). *Environmental Science and Policy* **12** (8), 1153–1167.
- Zhongzheng, L., Shaopeng, Q. & Huijun, G. 2003 Comprehensive evaluation of ecological environment quality in the upper reaches of the Yellow River and its source area. *Geo-Information Science* **5** (01), 11–15.

First received 1 June 2020; accepted in revised form 15 October 2020. Available online 28 October 2020