

Prediction of daily streamflow using artificial neural networks (ANNs), wavelet neural networks (WNNs), and adaptive neuro-fuzzy inference system (ANFIS) models

Hüseyin Yıldırım Dalkılıç and Said Ali Hashimi

ABSTRACT

In recent years, the prediction of hydrological processes for the sustainable use of water resources has been a focus of research by scientists in the field of hydrology and water resources. Therefore, in this study, the prediction of daily streamflow using the artificial neural network (ANN), wavelet neural network (WNN) and adaptive neuro-fuzzy inference system (ANFIS) models were taken into account to develop the efficiency and accuracy of the models' performances, compare their results and explain their outcomes for future study or use in hydrological processes. To validate the performance of the models, 70% (1996–2007) of the data were used to train them and 30% (2008–2011) of the data were used to test them. The estimated results of the models were evaluated by the root mean square error (RMSE), determination coefficient (R^2), Nash–Sutcliffe (NS), and RMSE-observation standard deviation ratio (RSR) evaluation indexes. Although the outcomes of the models were comparable, the WNN model with $RMSE = 0.700$, $R^2 = 0.971$, $NS = 0.927$, and $RSR = 0.270$ demonstrated the best performance compared to the ANN and ANFIS models.

Key words | daily streamflow, forecasting hydrological modeling, neural network

Hüseyin Yıldırım Dalkılıç (corresponding author)
Dept. Civil Engineering, Faculty of Engineering,
Erzincan Binali Yıldırım University,
Erzincan 24000,
Turkey
E-mail: hydalkilic@erzincan.edu.tr

Said Ali Hashimi
Graduate School of Natural and Applied Sciences,
Erzincan Binali Yıldırım University,
Erzincan 24000,
Turkey

INTRODUCTION

In recent years, streamflow prediction has been considered to be one of the most important issues in the fields of hydrology, water resources, and water resources management. An accurate streamflow estimation can play a positive role in enhancing the capacity of reservoirs, flood prevention, water supply, design of hydroelectric projects, and water resources management. It can therefore have a significant impact on reducing the effects of climatic events on the environment and improve the efficiency of the outcomes.

In the past few years, data-driven models, including artificial neural networks (ANNs), wavelet neural networks (WNNs), and adaptive neuro-fuzzy inference systems (ANFIS) models, have been applied as effective tools for

modeling nonlinear and complex hydrological systems (Wu *et al.* 2009; Seo *et al.* 2013a, 2013b; Seo & Kim 2016). Despite the wide usage of the ANN method to predict hydrological variables, it may not give accurate and reliable results in the estimation of unstable data. Therefore, to estimate a hydrologic time series comprising nonlinear relationships, the use of data pre-processing techniques is needed to improve the performance of ANNs (Okkan 2013). One of these methods is the wavelet transform, which is a signal processing technique. In contrast to Fourier transform, it is possible to calculate both the low- and high-frequency components of the signal at each time interval with wavelet transform. Many studies have achieved successful predictions with the WNN model, which is formed by combining wavelet analysis and ANN usage. Coulibaly & Burn (2004), Partal (2007) and Kisi (2009) used the streamflow values of the preceding days as an input parameter to estimate the streamflow of the Aegean

This is an Open Access article distributed under the terms of the Creative Commons Attribution Licence (CC BY 4.0), which permits copying, adaptation and redistribution, provided the original work is properly cited (<http://creativecommons.org/licenses/by/4.0/>).

doi: 10.2166/ws.2020.062

River and to develop the WNN model. They stated that WNN models have lower error values than ANN models.

ANFIS was first proposed by Jang (1993). It is also a powerful data-driven technique that can be used to model hydrologic processes such as rainfall-runoff forecasting and flood risk management. The basic construction of ANFIS is IF-THEN rules with appropriate membership functions to be able to generate input-output pairs. To model the flow of the Baitarani River in India, Nayak *et al.* (2004) made a prediction with ANFIS using the hydrological time series. In the estimation made with ANFIS, it was observed that the statistical characteristics of the original flow series were preserved and a successful estimation emerged.

These significant models used together in this study are better than a single model, as the models' forecasted results can be used to compare their forecasting ability and therefore recognize the powers and precision of each model for a given dataset. The multi artificial intelligence models for hydrological modeling that show the differences and compare the models' performances were applied in this study. To have a better conception of the estimated data through the models mentioned, some highly recommended and effective model evaluation indexes were applied in this study. Using these evaluation indexes, the root mean square error (RMSE), determination coefficient (R^2), Nash–Sutcliffe (NS), and RMSE-observation standard deviation ratio (RSR), the results can be readily interpreted and used as a reliable outcome for future studies or in hydrological processes.

This study aimed to determine the daily streamflow values of four different stations located on the Büyük Menderes River. This study developed and applied three different models to assess the efficiency and accuracy of each model in relation to the original (measured) data. Furthermore, the results of each model were comparable and did not have a significant difference. However, in terms of performance, WNN demonstrated the best performance compared to the ANFIS and ANN models.

STUDY AREA AND DATA

The Büyük Menderes River (historically the Maeander or Meander, from Ancient Greek) is the largest river in Western Anatolia and the main irrigation source in the

Menderes Basin: 79% of the water in the basin is used in the agriculture sector and in agricultural irrigation (Büyük Menderes Havza Atlası 2012). According to DSİ (1975) and EİE (1993) records, the length of the Büyük Menderes River is 584 km and has an area of 24,300 km². The river rises in Dinar, Afyonkarahisar province, (38° 4' 15" N, 30° 10' 37" E), at an elevation of 880 m.

Various inputs (mean temperature, precipitation, relative humidity, and the previous 3, 2, and 1 days' flow data) from the Muğla meteorological station were used to run the models. The streamflow monitoring stations E07A004, E07A0032, E07A0033, and E07A0037, which belong to the Electrical Power Resources Survey and Development Administration, are located near the Büyük Menderes River (Figure 1) and were chosen as they had not been much used in previous studies. This significant area has not been researched sufficiently to date, so the aim of this paper is to improve the productivity of the Büyük Menderes River as much as possible. The dataset for this study covers the period 1996 to 2011, as it is the most recent dataset available.

METHODS

ANNs

ANNs are a new information processing approach and they are one of the most popular subjects of contemporary science with their learning ability, adaptation, rapid operation, and ease of identification. ANNs are completely parallel distributed data processing systems that consist of a wide number of highly interconnected elements, called artificial neurons or nodes, which resemble the biological neural networks of the human brain (Tsoukala & Uhrig 1996). Neurons work on the principle of generating results by learning knowledge and increasing experience and information. Every neuron receives an input signal from another neuron that sends it through an activation or transfer function and utilizes an altered output to the other outputs (Figure 2). Even though each neuron implements its function rather slowly and imperfectly, a network can perform a wide number of tasks quite efficiently if they combine to work collectively. ANNs, which are nonlinear black-box

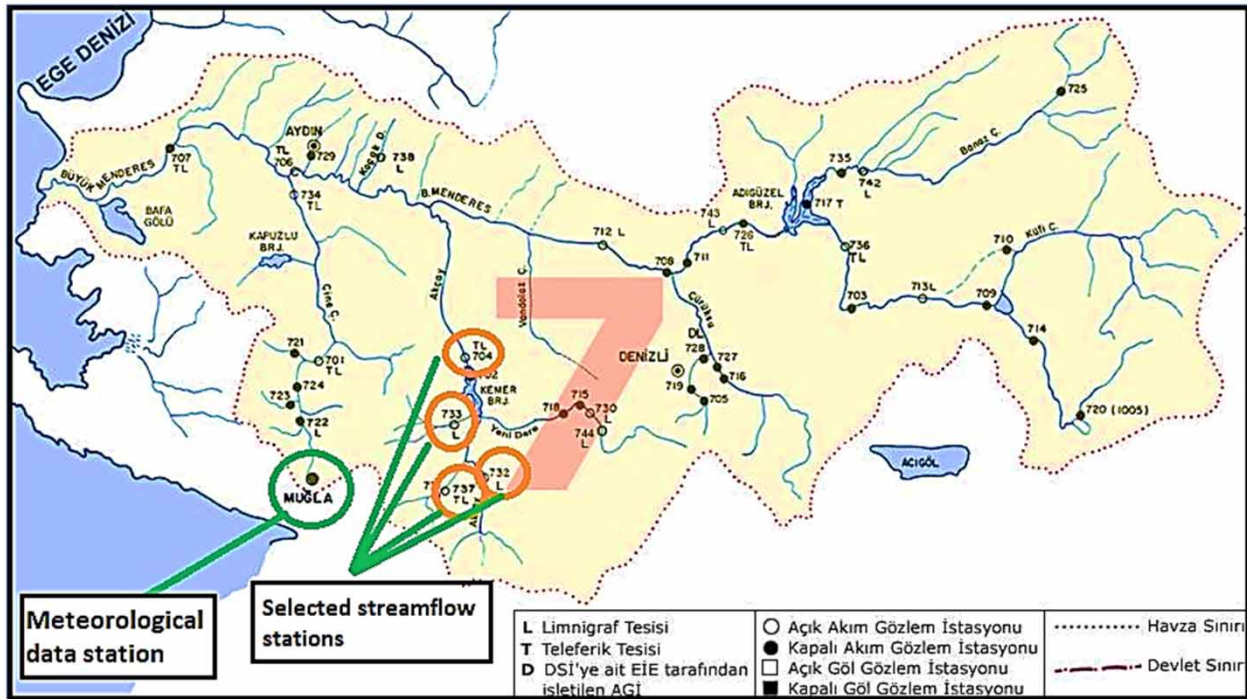

Figure 1 | The Büyük Menderes Basin.

models, are accepted as being amongst the most popular methods, especially in modeling, because of their precise and reliable results for the prediction of hydrological variables. Recently, ANNs have not been used regularly, as they do not present hydrological modeling results that are as successful and accurate as WNNs and ANFIS models. There are a few ANN models that have been proposed since the 1980s, and probably the most influential of them are the multi-layer perceptron (MLP), the Hopfield network, and Kohonen's self-organizing networks.

Feed forward neural network (FFNN)

The FFNN is the most commonly used neural network in water resources. It is generally used for forecasting hydrological variables and generates a general substructure for showing nonlinear operational surveying between a collection of input and output variables. Typically, it has two stages, forward and backward calculating and three layers of neural networks: input, output, and hidden layer. Each layer consists of many neurons that are connected by weight clusters, and their connection forms and number of

neurons can change in each layer. The relationship between forward computing and backward computing is acquired by the training procedures.

There are various backpropagation algorithms that have developed relevant techniques to train FFNN models. Backpropagation was developed by Paul Werbos in 1974 and is a supervised learning technique, based on the gradient descent (GD) method, which tries to minimize the errors produced by the neural network when it guesses data. The target of the backpropagation training process is to regulate the weights of the system to reduce the errors of the network.

$$E(W) = \frac{1}{2} \sum_{p=1}^P (d_p - y_p)^2 = \frac{1}{2} \sum_{p=1}^P (e_p)^2, P = mT \quad (1)$$

Here, T is the sum of training samples, the number of output layers is m , weights in the network are represented by W , and y_p and d_p are, respectively, the actual and desired outputs of the network. The alteration of weights can be calculated as below when the model is trained with the Levenberg-Marquardt algorithm, which is the most widely

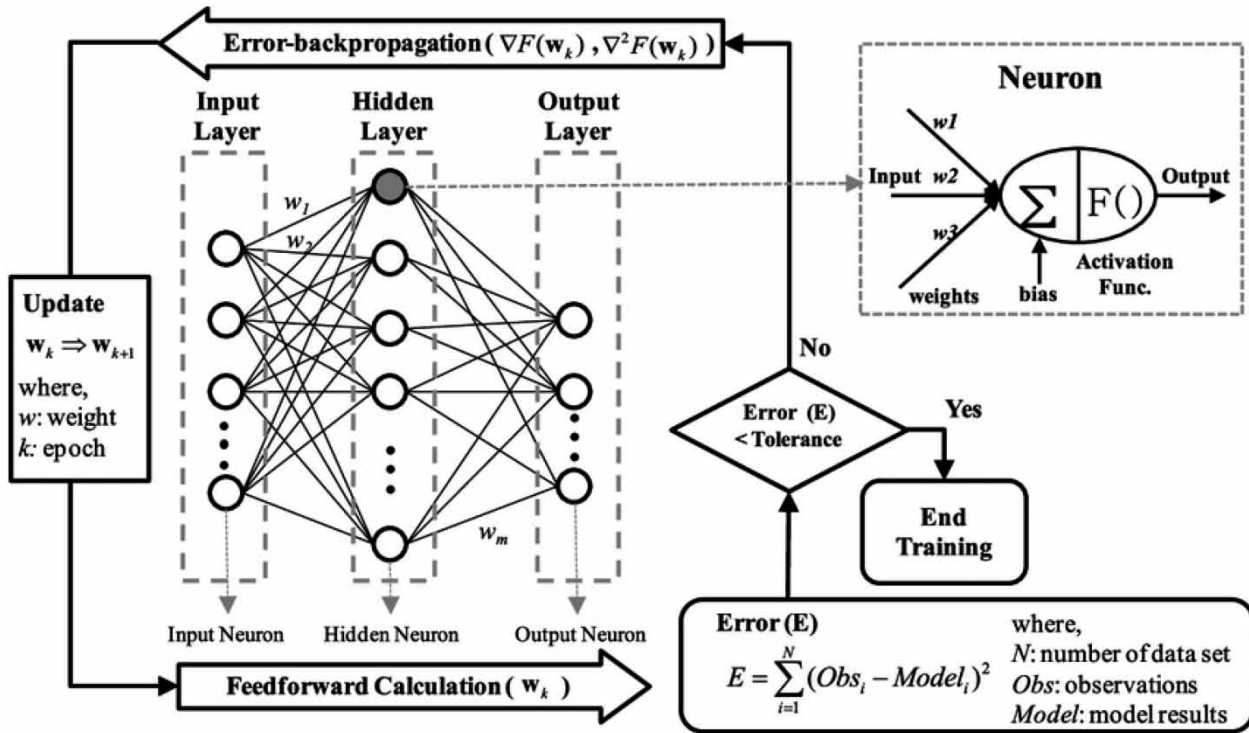

Figure 2 | Typical ANN and FFNN with a backpropagation training algorithm.

used optimization algorithm and is specifically designed to minimize the sum of square error functions. It has become a standard technique for nonlinear least-squares problems, widely adopted in various disciplines for dealing with data fitting applications. Furthermore, it gives the best performance in the prediction of daily streamflow compared to any other backpropagation algorithm.

$$\Delta W_k = -[J_k^T J_k + \mu_k I]^{-1} J_k^T e_k \tag{2}$$

Next, the upgrade of the weights is modified as below:

$$\Delta W_{k+1} = W_k + \Delta W_k \tag{3}$$

Here, J , I , e , μ are, respectively, the Jacobian matrix, identity matrix, network error, and Marquardt parameter that are to be updated using the decay rate β relay on the result. Further, μ is multiplied by the decay rate β ($0 < \beta < 1$) whenever $E(W)$ decreases, and $E(W)$ increases in a new step (Coulibaly *et al.* 2000).

In this study, the Levenberg-Marquardt backpropagation algorithm was used in the training of the FFNN. The Levenberg-Marquardt backpropagation algorithm is usually quicker and more reliable than any other backpropagation technique, and it is a second-order nonlinear optimization technique (Coulibaly *et al.* 2000; Kisi 2004; Fistikoglu & Okkan 2011). The Levenberg-Marquardt optimization algorithm shows a shortened version of the Newton method applied to the training phase of the FFNN.

As shown in Figure 2, the procedure of error-propagation contains two moves in different layers of the network. In the frontward movement, the input vector of the algorithm is applied to the neurons of the network, and in the backward movement, all of the weights are modified in line with the error-correction rule. Then the error signal spreads backward via the network and the weights are modified to make the actual response of the network closer to the desired response. K : epoch refers to the number of rounds of optimization applied during training. With more rounds of optimization, the error in the training data will reduce further and further until there is a constant

Table 1 | Variables for the ANN models using original runoff series (Station E07A0037)

Model inputs	Model structure	Training set				Test set			
		RMSE	MSE	R	R ²	RMSE	MSE	R	R ²
Q _{t-1}	(1,10,1)	3.09	9.58	0.77	0.60	1.87	3.5	0.96	0.91
Q _{t-2} , Q _{t-1}	(2,10,1)	2.98	8.90	0.90	0.81	2.60	6.75	0.89	0.79
Q _{t-3} , Q _{t-2} , Q _{t-1}	(3,10,1)	3.05	9.32	0.77	0.59	3.64	13.32	0.75	0.57
Q _{t-1} , P _t	(2,10,1)	2.98	8.86	0.79	0.63	2.24	5.03	0.86	0.75
Q _{t-1} , P _t , T _{avg(t)} , R _{h(t)}	(4,10,1)	2.92	8.52	0.82	0.67	2.21	4.91	0.85	0.72

number of errors. W : weight is the parameter within a neural network that transforms input data within the network's hidden layers. Bias is simply a constant value added to the product of inputs and weights. Bias is utilized to offset the result. The activation function is a mathematical function that can normalize the inputs of a network and the Error (E) is equal to the sum of the squared difference between observed data and the model's result as is shown in Figure 2.

Design of the ANN model

This study trained a neural network using 15 years (1996–2011) of daily flow data from four stations in the Büyük Menderes Basin to estimate the near future's daily streamflow. To increase the precision of the estimation process, 70% of the data was used for training and 30% of the data was used to test the model. The model's input parameters were precipitation, previous flow, average temperature, and relative humidity, which always show continuous variation. Parameters that change constantly are difficult to define in a mathematical model. Therefore, here, the ANN method was used for the solution of nonlinear problems. The ANN model was designed as an FFNN and it consisted of different inputs (Q_{t-3}, Q_{t-2}, Q_{t-1}, P_t, T_{avg(t)}, R_{h(t)}, and one output (Q_t). Here, t is the time (daily); Q_{t-3}, Q_{t-2}, Q_{t-1} are defined as the flow rate in the previous 3, 2, and 1 days; P_t is the precipitation; and T_{avg(t)} and R_{h(t)} are the average temperature and relative humidity, respectively. The designed structure of the ANN model consisted of three layers and 10 neurons in its hidden layers. In the trial and error studies of the ANN model, the most effective and minimum error rate of results were obtained with 10 neurons

and three layers using the MATLAB (v.R2018a) program. The network is based on the backpropagation model, correcting the error in the network by spreading it backward. In this model, the Levenberg-Marquardt optimization was used as the training algorithm. Using these methods together, the weight values of ANN were calculated in epochs.

The training process is the re-determination of the weights to minimize the error between the results obtained from the output and the expected values in each iteration of the epochs. Here, the mean square error (MSE) function was used as the error reduction function. The model's inputs that involved Q_{t-2}, Q_{t-1}, and Q_{t-1} inputs, developed to estimate the daily streamflow, demonstrated the best performance as shown below. Here, the ANN (1,10,1) model structure shows that there is one cell in the input layer, 10 in the hidden layer, and one in the output layer. When the models developed are examined, the first two statistical parameters in Table 1 give a close correlation value. The third statistical parameter has the biggest error value among the other parameters used in Station E07A0037.

WNNS

The WNN model is formed by the application of discrete wavelet transform (DWT), which is an implementation of the wavelet transform using a discrete set of the wavelet scales and translations acting by some predetermined rules. In other words, the significant features of many natural signals are captured by a subset of DWT coefficients that is normally much smaller than the original signal, and the ANN method, and it is a neural network prediction algorithm that stands based on wavelet theory. Among the

functions of the WNN, one of the most significant is the estimation function. Neurons are replaced in the hidden layer of the neural network with the scaling function to have more space and therefore have a stronger function approximation ability (Khodadadi & Razavi 2012). A wavelet network is trained to learn the composition of an observed data function and to calculate an expected value for a given value. It has also the ability of self-learning, adaptivity, and calculating the nonlinear parameters of a system (Hou *et al.* 2013). Compared to the traditional backpropagation neural network, the wavelet network can compensate for the deficiencies of the incomplete information extraction of the conventional neural network, due to the time-frequency localization capability of the wavelet function (Heinermann & Kramer 2016). To set up the WNN model, the original time series is subdivided using a DWT, then each sub-series obtained behaves differently from the original series. Then, the correlation coefficients are calculated between the obtained sub-series and the model output. The WNN inputs are determined by appropriate sub-series according to the correlation coefficient values. Common wavelets used in the wavelet analysis are Haar Shannon, Mexican Hat, Coiflet, Daubechies 4, Daubechies 20, Gaussian and Biorthogonal wavelets and are shown in Figure 3.

The main advantage of using wavelets is that they are localized in space. Generally, their applications are data processing, data compression, and the solution of differential equations. In this study, the Haar wavelet is used for the WNN model, and it is the simplest, most easily imaginable and the earliest of the wavelet family. The wavelet function of the Haar wavelet is as follows:

$$\psi(x) = \begin{cases} 1 & 0 \leq x < 1/2, \\ -1 & 1/2 \leq x < 1, \\ 0 & \text{otherwise,} \end{cases} \quad (4)$$

The scaling function of Haar wavelet is:

$$\varphi(x) = \begin{cases} 1 & 0 \leq x < 1, \\ 0 & \text{otherwise,} \end{cases} \quad (5)$$

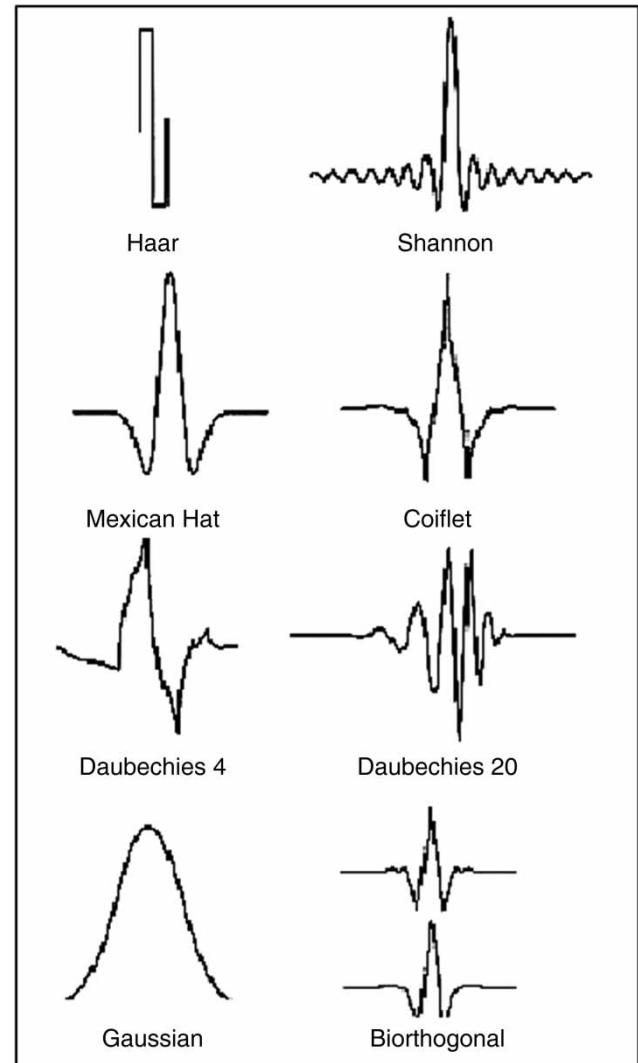

Figure 3 | Different type of wavelets.

The working rules of WNNs

Firstly, daily meteorological data (average temperature, relative humidity, and total precipitation) were divided into five details (2-4-8-16-32 daily periodic components), and one approximation component using DWT. With the help of the algorithm given by Mallat (1989), the original data (signal) are divided into several series, called approximation and detail components (AD), and the original data are recovered again by a collection of these series in a row.

The first level of detail component is named AD1 and refers to the 2-day scale component. This gives us the highest frequency variations. AD5 is the lowest frequency detail component and has a 32-day scale. It is necessary to determine which AD components have to be selected to obtain the desired successful results in streamflow prediction with the ANN. For this purpose, the correlations between the AD components and the original streamflow were calculated. Table 2 shows the results obtained for Station E07A0037.

To develop the streamflow estimation models, three different input combinations that are dependent on the previous periods of the streamflow were evaluated. These input combinations were as follows: (1) Q_{t-3} , Q_{t-2} , Q_{t-1} ; (2) Q_{t-2} , Q_{t-1} ; (3) Q_{t-1} ; (4) Q_{t-1} , P_t ; and (5) Q_{t-1} , P_t , $T_{avg}(t)$, $R_h(t)$. To assess the performance of the ANN and WNN models, the MSE, the mean absolute error (MAE), the correlation coefficient (R), and the R^2 values were used between the model results and measured data. Here, the Levenberg-Marquardt method was chosen as the learning algorithm. The WNN model was developed by sub-series as an input parameter, which was obtained with the Haar wavelet from the ANN model, as in the literature reviewed. Adamowski & Chan (2011), Kisi & Partal (2011), and Tiwari & Chatterjee (2011) collected the sub-series

obtained from the DWT in their studies and used them as inputs for the ANN model. The statistical parameters of the training and test sets of the WNN models that were developed are shown here just for one station, E07A0037, in Table 3.

ANFIS

Various methods have been used to organize a relationship between several variables, for example: ANNs, linear regression (LR), nonlinear regression (NLR), fuzzy inference systems (FIS), and a combination of neural networks and FIS that are known as adaptive neuro-fuzzy systems (ANFIS), introduced by Jang (1993). Both FIS and ANNs methods have their weaknesses for training data and showing a desirable result. ANFIS has created a combination of the ability to generate the fuzzy rules of FIS models and the ability to train the network model of ANN, which can overcome the disadvantages of each of these models. Thus, ANFIS can provide better results with fewer restrictions than ANN and FIS models in a variety of fields, including groundwater studies, such as in the estimation of hydraulic parameters. The ANFIS structure has five layers. First layer, input nodes: Each node of this layer creates

Table 2 | Approximation and detail (AD) components for Station E07A0037, each with measured streamflow data correlation coefficients

AD components	Q_{t-3}	Q_{t-2}	Q_{t-1}	P_t	$T_{avg}(t)$	$R_h(t)$
D1	-0.018	-0.097	0.325	0.190	0.023	0.007
D2	-0.023	-0.019	0.326	0.176	0.022	-0.015
D3	0.144	0.260	0.408	0.289	-0.033	-0.003
D4	0.044	0.165	0.361	0.231	-0.059	0.013
D5	0.253	0.271	0.301	0.197	-0.073	-0.022
A5	0.597	0.610	0.634	0.516	-0.310	-0.270

Table 3 | Variables for WNN (Haar) models using the sum of runoff sub-series (Station E07A0037)

Statistical parameters	Model structure	Training set				Test set			
		RMSE	MSE	R	R^2	RMSE	MSE	R	R^2
Q_{t-1} (D1+D2+D3+D4+A5)	(1,10,1)	2.57	6.63	0.94	0.89	1.09	1.18	0.97	0.93
Q_{t-2} , Q_{t-1} (D3+D5+A5)	(2,10,1)	2.54	6.45	0.84	0.71	1.14	1.30	0.96	0.93
Q_{t-3} , Q_{t-2} , Q_{t-1} (D5+A5)	(3,10,1)	2.58	6.68	0.84	0.70	0.70	0.49	0.98	0.97
Q_{t-1} , P_t (D1+D2+D3+D4+A5)	(2,10,1)	2.40	5.74	0.86	0.75	1.06	1.13	0.97	0.94
Q_{t-1} , P_t , $T_{avg}(t)$, $R_h(t)$ (D1+D2+D3+D4+A5)	(4,10,1)	2.29	5.27	0.87	0.76	1.04	1.08	0.97	0.94

membership values that depend on each of the suitable fuzzy sets, using the membership function.

$$O_{1,i} = \mu A(x) \quad \text{for } i = 1, 2 \tag{6}$$

$$O_{1,i} = \mu B(y) \quad \text{for } i = 3, 4 \tag{7}$$

where non-fuzzy x and y entries to nodes A and B are linguistic labels that are specified by μA_i and μB_i membership functions respectively. These functions are symbolized by O.

The second layer, base nodes: Each neuron is fixed in this layer and the AND or the OR operator is applied to obtain one output that represents the result of the antecedent for that rule, i.e., firing strength. This layer is the product of the degrees of the first layer of O_{2k} outputs, whose equation is as follows:

$$O_{2,1} = w_i = \mu A_i(x)\mu B_i(y), \quad i = 1, 2 \tag{8}$$

The third layer, medium nodes: The main purpose of the third layer is to determine the ratio of each ignition factor I to the sum of all ignition laws. As a result, w is obtained as a standardized ignition source.

$$O_{3,i} = \dot{w}_i = \frac{w_i}{w_1 + w_2} \tag{9}$$

The fourth layer, results nodes: the output of each layer is equal to:

$$O_{4,i} = \dot{w}_i f_i = w_i(p_i x + q_i y + r_i) \tag{10}$$

In this relation w_i is the output of the antecedent layer and p_i, r_i, q_i are the linear coefficients of combination. Also, the total parameters of the tail section are Takagi-Sugeno fuzzy models. The fifth layer, output nodes: This layer calculates the signal node of the total output by collecting all the input signals. Therefore, in this layer of inactivity, the results of each fuzzy rule are transformed into non-fuzzy output.

$$O_{5,i} = \sum_{i=1}^2 \dot{w}_i f_i \tag{11}$$

The network is trained based on learning with supervision. So, the target is to teach ANFIS to estimate uncertain functions derived from instructional information and accurately estimate the unknown parameters (Figure 3). To design an ANFIS model, it was not easy to select a better fuzzy inference system for a specific goal. Different types of FIS have been stated in the literature (Takagi & Sugeno 1985). The adaptive neuro-fuzzy system is usually used with the Sugeno fuzzy system as a progressive network structure, as presented in Figure 4.

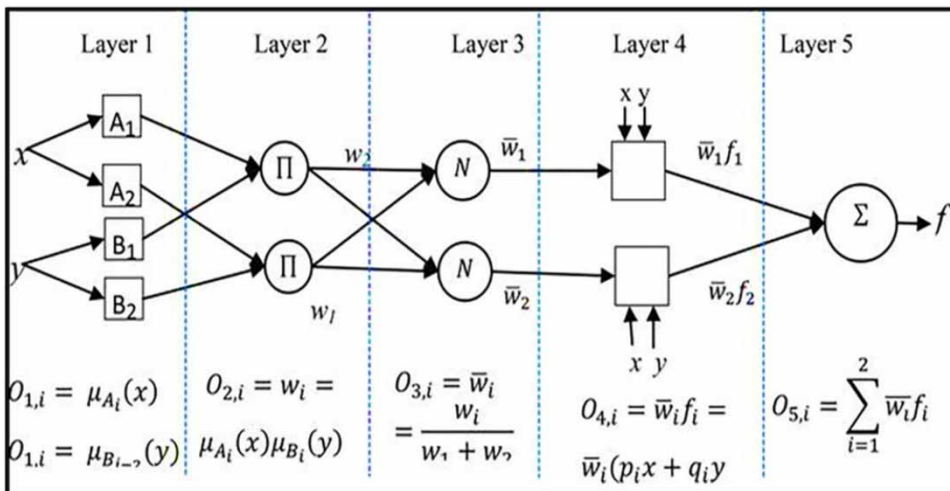

Figure 4 | ANFIS network structure.

Table 4 | Variables for the ANFIS model using original runoff series (Station E07A0037)

Statistical parameters	Train opt. method FIS	Training set				Test set			
		RMSE	MSE	R	R ²	RMSE	MSE	R	R ²
Q _{t-1}	Backpropagation	2.97	8.80	0.81	0.80	2.45	6.02	0.84	0.87
Q _{t-2} , Q _{t-1}	Backpropagation	2.93	8.80	0.80	0.81	2.45	6.01	0.84	0.88
Q _{t-3} , Q _{t-2} , Q _{t-1}	Backpropagation	2.86	8.15	0.81	0.65	2.44	5.97	0.84	0.89
Q _{t-1} , P _t	Backpropagation	2.93	8.59	0.80	0.80	2.33	5.44	0.84	0.86
Q _{t-1} , P _t , T _{avg(t)} , R _{h(t)}	Backpropagation	2.92	8.54	0.80	0.80	2.45	6.02	0.83	0.69

Here, for generating an FIS, various membership function types were evaluated, and the most effective membership function type (trimf) for input data and output data (linear) shows the best results for all four different stations. To train the FIS, the backpropagation method was used to cope with the parameter recognition problem in an FIS, which is the basic rule of an adaptive network, and based on a descent rule that can successfully estimate the parameters. The outcomes for the ANFIS model gained are shown in Table 4. On the other hand, the characteristics of the model's performance criteria, that the outputs of the models examined by the evaluators, fortunately remained between those ranges that are shown in Table 5.

RESULT AND DISCUSSION

In this study, to estimate daily streamflow values, three models, ANN, WNN, and ANFIS, were used in four different stations located near the Büyük Menderes River. RMSE, R², NS, and RSR were used as the evaluation indicators of the models' outcomes to represent the satisfaction or dissatisfaction ratio of the models. Therefore, the best consequence from different parameters of the models' tests

Table 5 | The evaluators' ranges of validation for the models' outputs (ANN, WNN, and ANFIS)

Evaluators	Ranges	Satisfactory	Unsatisfactory	Model result
RMSE	0 to +∞	x ≤ 0.5	x ≥ 0.5	✓
R ²	0 to +1	x ≥ 0.5	x ≤ 0.5	✓
NS	-∞ to +1	x ≥ 0.5	x ≤ 0.5	✓
RSR	0 to +∞	x ≤ 0.5	x ≥ 0.5	✓

for the ANN are listed in Table 6, for the WNN in Table 7, and for the ANFIS in Table 8. The input data were classified into five parameters and each parameter had one or more than one combination of the input data, which were considered to be the same for the four stations used in this study. Despite presenting the most important details about each model's structures and development processes for estimating daily streamflow, it is better to sum over each model's performance and quality individually. The most important step in modeling is choosing the right combination of input variables. Thus, the correlation between input variables and output was calculated, and the input variables were selected to model the system to estimate the daily streamflow of the Büyük Menderes River, as shown in Table 6.

In this table, the parameters of the flow of the previous 1, 2, and 3 days, precipitation, average temperature, and

Table 6 | The correlation between the input and output parameters

	Q _{t-1}	Q _{t-2}	Q _{t-3}	P _t	T _{avg(t)}	R _{h(t)}
Q _t	0.95	0.71	0.65	0.60	-0.31	-0.25

Table 7 | Five different combinations of input and one output

Input	Output
Q _{t-3} , Q _{t-2} , Q _{t-1}	Q _t
Q _{t-2} , Q _{t-1}	
Q _{t-1}	
Q _{t-1} , P _t	
Q _{t-1} , P _t , T _{avg(t)} , R _{h(t)}	

Table 8 | The best result for streamflow prediction using the ANN

Stations (m ³ /s)	Network archit.	RMSE (m ³ /sec)		R ²		NS		RSR	
		Train	Test	Train	Test	Train	Test	Train	Test
E07A004	3-10-1	14.015	4.466	0.864	0.932	0.623	0.931	0.614	0.262
E07A0032	1-10-1	16.093	10.423	0.919	0.785	0.391	0.538	0.780	0.680
E07A0033	2-10-1	2.134	2.238	0.593	0.856	0.418	0.548	0.763	0.672
E07A0037	1-10-1	3.096	1.870	0.599	0.915	0.516	0.785	0.695	0.464

relative humidity were the inputs in a period of (t) and flow as an output in a period of (t) were described. According to the meaningful correlation between the inputs and output, which are shown above, a few different combinations of input parameters were used to estimate the daily streamflow values efficiently that are shown in Table 7.

As is shown in Table 8, the best result was for the ANN, as demonstrated by the minimum error rate, RMSE = 4.466, and by the best correlation rate, R² = 0.932, which includes three input layers, 10 hidden layers, and one output layer. Additionally, as can be seen from Table 9, the WNN model also performed well, with the minimum error rate,

RMSE = 0.700, and the best correlation rate, R² = 0.971, which refers to the most precise correlation value. Furthermore, as shown in Table 10, the ANFIS model result is also considered to be good, with the minimum error rate of RMSE = 5.068, and the best correlation rate of R² = 0.947. Figure 5 shows the time series and plot graphs of the models. The correlation and proximity of all the models' outcomes (output) with the observed (original) output of the data once again can be observed in Figure 6. The study aimed to find the minimum error rate, and conversely the highest correlation rate, for the observed output through modeling the data.

Table 9 | The best result for streamflow prediction using the WNN

Stations (m ³ /s)	Network archit.	RMSE (m ³ /sec)		R ²		NS		RSR	
		Train	Test	Train	Test	Train	Test	Train	Test
E07A004	2-10-1	7.642	6.072	0.918	0.884	0.888	0.873	0.335	0.356
E07A0032	1-10-1	14.655	9.359	0.566	0.949	0.555	0.852	0.667	0.385
E07A0033	4-10-1	1.587	1.047	0.688	0.854	0.682	0.852	0.564	0.385
E07A0037	1-10-1	0.585	0.700	0.705	0.971	0.665	0.927	0.579	0.270

Table 10 | The best result for streamflow prediction using the ANFIS

Stations (m ³ /s)	Network archit.	RMSE (m ³ /sec)		R ²		NS		RSR	
		Train	Test	Train	Test	Train	Test	Train	Test
E07A004	3-10-1	7.159	5.068	0.939	0.914	0.902	0.912	0.313	0.297
E07A0032	2-10-1	16.049	10.119	0.918	0.947	0.394	0.564	0.778	0.660
E07A0033	1-10-1	2.160	1.947	0.906	0.888	0.411	0.487	0.767	0.716
E07A0037	3-10-1	2.856	2.444	0.654	0.886	0.585	0.632	0.644	0.606

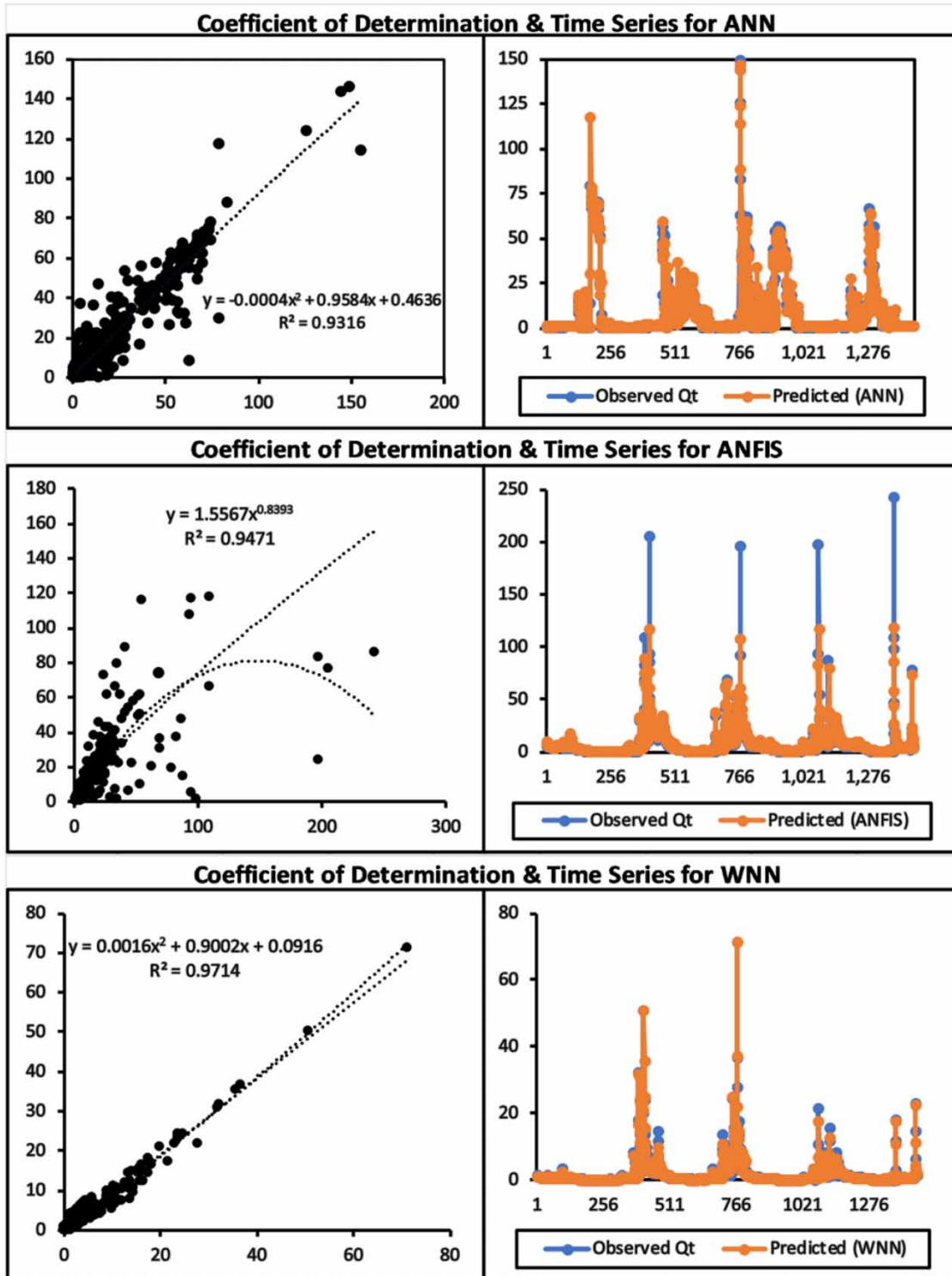

Figure 5 | Time series and scatter plot for ANN (E07A004), WNN (E07A0037) and ANFIS (E07A0032).

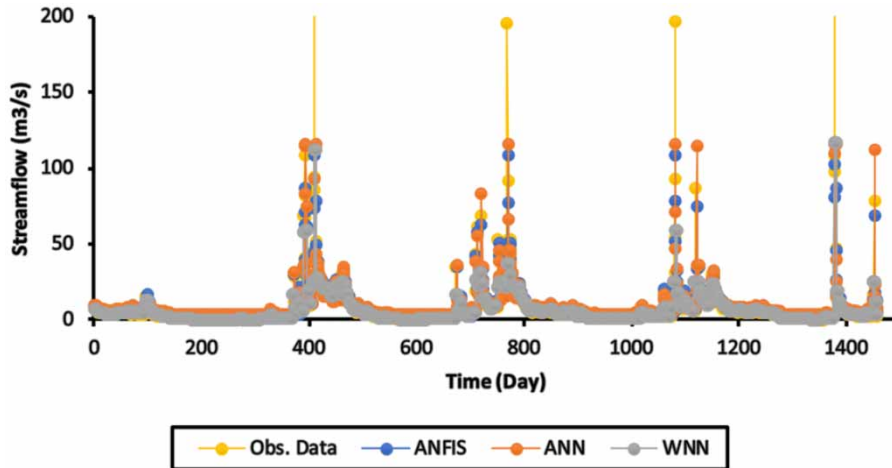

Figure 6 | The proximity of the model's output and observed (original) output.

CONCLUSIONS

The main purpose of the study was to achieve the minimum error rate, and conversely the highest correlation coefficient between the calculated data and the observed data using ANN, WNN and ANFIS models. As shown, the outcomes of the models were meaningful and successful by the end of the calculations. Simultaneously, assembling the most recommended models that are commonly cited in the literature was the other reason to understand and show the performances of the models through sequencing their outcomes by their precision rates.

The data were divided into 70% for training, 30% for testing the network, and the number of hidden neurons were selected by the trail-test method, which is considered to be 10 neurons in this study. The training algorithm selected for this model was the Levenberg-Marquardt because it is quicker than other algorithms, and it is the preferred algorithm for estimating a large number of daily intervals of data. To increase the performance and accuracy of the ANN model, the original data were decomposed into sub-series, their noises removed and the most efficient data were selected by calculating the correlation coefficients for each of the given parameters. ANFIS is a combination model of FIS and ANN. Each one has its positive aspects, and when they are joined together, the ANFIS model performs better. As a result, in this study, the WNN showed the most accurate result, with $R^2 = 0.971$, compared to the

two other models. The ANFIS model, with $R^2 = 0.947$, and the ANN model, with $R^2 = 0.932$, were second and third in this study. Briefly, the main reason that WNN gave the most accurate result was that decomposing the original data into sub-series and removing their noises, and again using them as clean data, significantly affected the outcomes.

REFERENCES

- Adamowski, J. & Chan, H. F. 2011 *A wavelet neural network conjunction model for groundwater level forecasting*. *Journal of Hydrology* **407**, 28–40. <https://doi.org/10.1016/j.jhydrol.2011.06.013>.
- Büyük Menderes Havza Atlası 2012 *Yaşayan Nehirler Yaşayan Ege Projesi (The Project of Living Rivers Living Aegean)*. S Basım Sanayi ve Ticaret Ltd. Şti.
- Coulibaly, P., Anctil, F. & Bobee, B. 2000 *Daily reservoir inflow forecasting using artificial neural network with stopped training approach*. *Journal of Hydrology* **230** (3–4), 244–257. [https://doi.org/10.1016/S0022-1694\(00\)00214-6](https://doi.org/10.1016/S0022-1694(00)00214-6).
- Coulibaly, P. & Burn, D. H. 2004 *Wavelet analysis of variability in annual Canadian stream flows*. *Water Resources Research* **47**, 1–14.
- DSİ 1975 *Aşağı Büyük Menderes Havzası Hidrojeoloji incelemesi (An Hydrogeological Investigation of Büyük Menderes Basin)*. Devlet Su İşleri Raporu (State Hydraulic Works Report), Ankara, p. 207 s.
- EİE 1993 *Türkiye akarsularında sediment gözlemleri ve sediment taşınım miktarları (Sediment transport amount and sediment observations in rivers of Turkey)*. Elektrik İşleri Etüd İdaresi Genel Müdürlüğü (General Directorate of Electrical Works Survey Administration), Yayın no. 93-59, Ankara.

- Fistikoglu, O. & Okkan, U. 2011 Statistical downscaling of monthly precipitation using NCEP/NCAR reanalysis data for Tahtali River Basin in Turkey. *Journal of Hydrologic Engineering* **16** (2), 157–164. [https://doi.org/10.1061/\(ASCE\)HE.1943-5584.0000300](https://doi.org/10.1061/(ASCE)HE.1943-5584.0000300).
- Heinermann, J. & Kramer, O. 2016 Machine learning ensembles for wind power prediction. *Renewable Energy* **89**, 671–679. <https://doi.org/10.1016/j.renene.2015.11.073>.
- Hou, Z., Lu, W. & Chen, S. 2013 Research on precipitation prediction based on WNN. *Water Saving Irrigation* **37** (03), 31–34.
- Jang, J. 1993 ANFIS: adaptive-network-based fuzzy inference system. *IEEE Transactions on Systems, Man, and Cybernetics* **23**, 665–685.
- Khodadadi, H. & Razavi, A. 2012 Comparison between neural networks and wavelet networks in nonlinear system identification. *Research Journal of Applied Sciences, Engineering and Technology* **4** (9), 1021–1026.
- Kisi, O. 2004 Multi-layer perceptron with Levenberg-Marquardt training algorithm for suspended sediment concentration prediction and estimation. *Hydrological Science Journal* 1025–1040. <https://doi.org/10.1623/hysj.49.6.1025.55720>.
- Kisi, O. 2009 Neural network and wavelet conjunction model for intermittent streamflow forecasting. *Journal of Hydrologic Engineering* **14** (8), 773–782. doi:10.1061/(ASCE)HE.1943-5584.0000053.
- Kisi, O. & Partal, T. 2011 Wavelet and neuro-fuzzy conjunction model for streamflow forecasting. *Hydrology Research* **42** (6), 447–456. <https://doi.org/10.2166/nh.2011.048>.
- Mallat, S. G. 1989 A theory for multiresolution signal decomposition: the wavelet representation. *IEEE Transactions on Pattern Analysis and Machine Intelligence* **11** (7), 674–693.
- Nayak, P. C., Sudheer, K. P., Rangan, D. M. & Ramasastri, K. S. 2004 A neuro-fuzzy computing technique for modeling hydrological time series. *Journal of Hydrology* **291** (1), 52–66. <https://doi.org/10.1016/j.jhydrol.2003.12.010>.
- Okkan, U. 2013 Wavelet neural network model for reservoir inflow prediction. *Scientia Iranica* **19** (6), 1445–1455. <https://doi.org/10.1016/j.scient.2012.10.009>.
- Partal, T. 2007 Türkiye yağış miktarlarının yapay sinir ağları ve dalgacık dönüşümü yöntemleri ile tahmini. Doktora tezi, İTÜ Fen Bilimleri Enstitüsü, İstanbul.
- Seo, Y. & Kim, S. 2016 River stage forecasting using wavelet packet decomposition and data-driven models. *Procedia Engineering* **154**, 1225–1230. <https://doi.org/10.1016/j.proeng.2016.07.439>.
- Seo, Y., Park, K. B., Kim, S. & Singh, V. P. 2013a Application of bootstrap-based artificial neural networks to flood forecasting and uncertainty assessment. In: *Proceedings of 6th International Perspective on Water Resources and the Environment, EWRI-ASCE*, Izmir, Turkey, pp. 1–10.
- Seo, Y., Kim, S. & Singh, V. P. 2013b Flood forecasting and uncertainty assessment using bootstrapped ANFIS. In: *Proceedings of 6th Conference of Asia Pacific Association of Hydrology and Water Resources*, Seoul, South Korea, pp. 1–8.
- Takagi, T. & Sugeno, M. 1985 Fuzzy identification of systems and its application to modeling and control. *IEEE Transactions on Systems, Man and Cybernetics* **15** (1), 116–132.
- Tiwari, M. K. & Chatterjee, C. 2011 A new waveletbootstrap-ANN hybrid model for daily discharge forecasting. *Journal of Hydroinformatics* **13** (3), 500–519.
- Tsoukala, L. H. & Uhrig, R. E. 1996 *Fuzzy and Neural Approaches in Engineering*. Wiley, NY, p. 587.
- Wu, C. L., Chau, K. W. & Li, Y. S. 2009 Predicting monthly streamflow using data-driven models coupled with data-preprocessing techniques. *Water Resources Research* **45** (8), W08432. <https://doi.org/10.1029/2007WR006737>.

First received 15 November 2019; accepted in revised form 20 March 2020. Available online 15 April 2020