

Real-time monitoring of water level and storage dynamics of irrigation tank using IoT

Muthiah Krishnaveni^{a,*}, S. K. Praveen Kumar^a, E. Arul Muthusamy^b, J. Kowshick^a and K. G. Arunya^a

^a Centre for Water Resources, Anna University, Chennai, India

^b Electronics and Communication Engineering, Anna University, Chennai, India

*Corresponding author. E-mail: mkveni@annauniv.edu

Abstract

The internet of things (IoT), an emerging technological marvel, consists of a group of physical objects such as vehicles, machines and sensors to monitor and transfer data over the internet with much less human to machine interaction. It relies on a host of technologies like application programming interfaces (API), which in turn, help the devices to get connected with the internet. Efficient irrigation tank management requires a strong database on continuous water level dynamics for irrigation decision-making. Real-time tank water level monitoring is possible through an IoT device by integrating sensors and microcontroller that can send the water level data to the cloud. Google sheet is used to store the water level data that can be viewed using a web application as well as a mobile application. The contour map of the study tank is used to develop the stage (water level) vs volume curve. The volume of water present in the tank at any time can be arrived at for any tank water level using the above curve. The developed device can provide real-time continuous water level data with low cost and simple infrastructure, thus aiding tank water management.

Key words: internet of things, irrigation tank, real-time monitoring, sensor technology

Highlights

- The present study attempts to demonstrate the use of IoT technologies for the automated process of the real-time water level monitoring of an irrigation tank.
- An IoT device is developed by integrating sensors and microcontroller which can sense and send the real-time tank water level data to the cloud.
- The developed low cost IoT-based device will sense, analyse and provide the continuous data on water level and storage dynamics to the user departments and farmers for decision making. It can also be extended as a flood monitoring device to alert farmers in the command area of the irrigation tank.

INTRODUCTION

India is well endowed with sufficient average rainfall of 1,215 mm per annum which is not distributed throughout the year. Eighty per cent of rainfall occurs during monsoon and 50% of this rainfall occurs during approximately 15 days of this monsoon period. India has the world's second largest irrigated area, accounting for about 64.57 Mha of which the area irrigated under tank irrigation is about 2.25 Mha. There are about 127,000 tanks in the southern region consisting of Andhra Pradesh, Tamil Nadu and Karnataka state. Tamil Nadu is a water-scarce state with annual per capita water availability of about 900 cm³ as against India's average of 2,200 cm³ (Anbumozhi *et al.* 2001). Most of the rivers in Tamil Nadu flow only during the monsoon season and it is not possible to construct more large-scale reservoirs due to the flat landscape (Arumugam *et al.* 2009). This has led to the construction of as many as 39,000 tanks as localized water harvesting structures. Most of the tank system is mainly used for irrigation purposes. Tanks are mostly managed by the local communities as a common property resource. Since tank irrigation systems are less capital-intensive and have a large geographical distribution, they are of special significance to a large number of small and marginal farmers (Gunnell & Krishnamurthy 2003).

Sustainable management of tank irrigation systems requires hydrological and meteorological data (Kortuem *et al.* 2010). The hydro-meteorological data are essential to estimate crop water requirement and to plan irrigation scheduling. Proper tank operation for irrigation release during normal, flood and drought periods essentially necessitates the water balance study of the tank on a daily basis. These data are rarely monitored and available in the case of tank systems. Thus, a cost-effective device using modern technology such as the internet of things (IoT) is necessary for the effective management of the tank irrigation systems of India.

IoT integrates the physical world with the virtual world by using the internet as the medium to communicate and exchange information (Mohammed Shahanas & Bagavathi Sivakumar 2016). It integrates several technologies that already exist, such as wireless sensor network (WSN), radio frequency (RF) identification, cloud computing, middleware systems and end-user applications. The capability of WSN to self-organize, self-configure, self-diagnose and self-heal has made it a good choice for smart agriculture and the food industry (Palanisami & Nanthakumaran 2009). It revolves around increased machine-to-machine communication and reduced human-to-human or human-to-computer interaction. It enables new forms of communication between people and things, and between things themselves. It is possible to monitor, transfer and store the data in real time. Thus, IoT helps various organizations and individuals to access information towards facilitating major decision-making processes. As such, the present study attempts to demonstrate the use of IoT technologies for the automated process of sensing the real-time data of water level of an irrigation tank. The developed IoT-based irrigation tank water level monitoring device will measure, analyse and provide a decision-supporting platform for the farmers.

The usefulness of IoT applications in various domains including water, medical, manufacturing, industrial, transportation, education, governance and mining is being explored. Several researchers have addressed the use of IoT in agriculture to enhance the different agricultural processes (Palanisami 2006). Zhu & Lin (2012) emphasized mostly the use of cloud enabled systems to show the relationship between the information cloud and IoT from the view point of agricultural data and its use cases. They argue that intelligent agriculture is one of the applications of IoT that has an extensive application and bright future (Patil *et al.* 2017). Khaled Reza *et al.* (2010) developed a device that could automatically control the water level in an overhead tank by switching on and off the pump using IoT (Govindasamy & Balasubramanian 1990). Mohammed Shahanas & Bagavathi Sivakumar (2016) framed an algorithm to monitor the water level dynamics in the overhead tank of a gated apartment community as an initiative to smart water management in smart cities of India (Shanmugam 2012).

Conventionally, the water level in irrigation tanks is noted and recorded manually. This involves human error and this information will not be available to farmers and researchers. This paper illustrates the novel idea of real-time monitoring of water level dynamics of an irrigation tank through IoT. In addition to this, the humidity and temperature data are also measured using the relevant sensors. All these data can be shared with farmers, administrators and researchers digitally to assess the water balance and plan the optimal use of tank water.

STUDY AREA

The study tank chosen is the Melnelli big tank in Arcot taluk of Vellore district, Tamil Nadu which is located at latitude 12°43'45" N and longitude 79°28'10" E. The spatial spread of the catchment, water spread and the command areas of the irrigation tank are shown in Figure 1. The original storage capacity of the tank at full tank level (FTL) is 1.40 Mm³. However, the current capacity of the tank

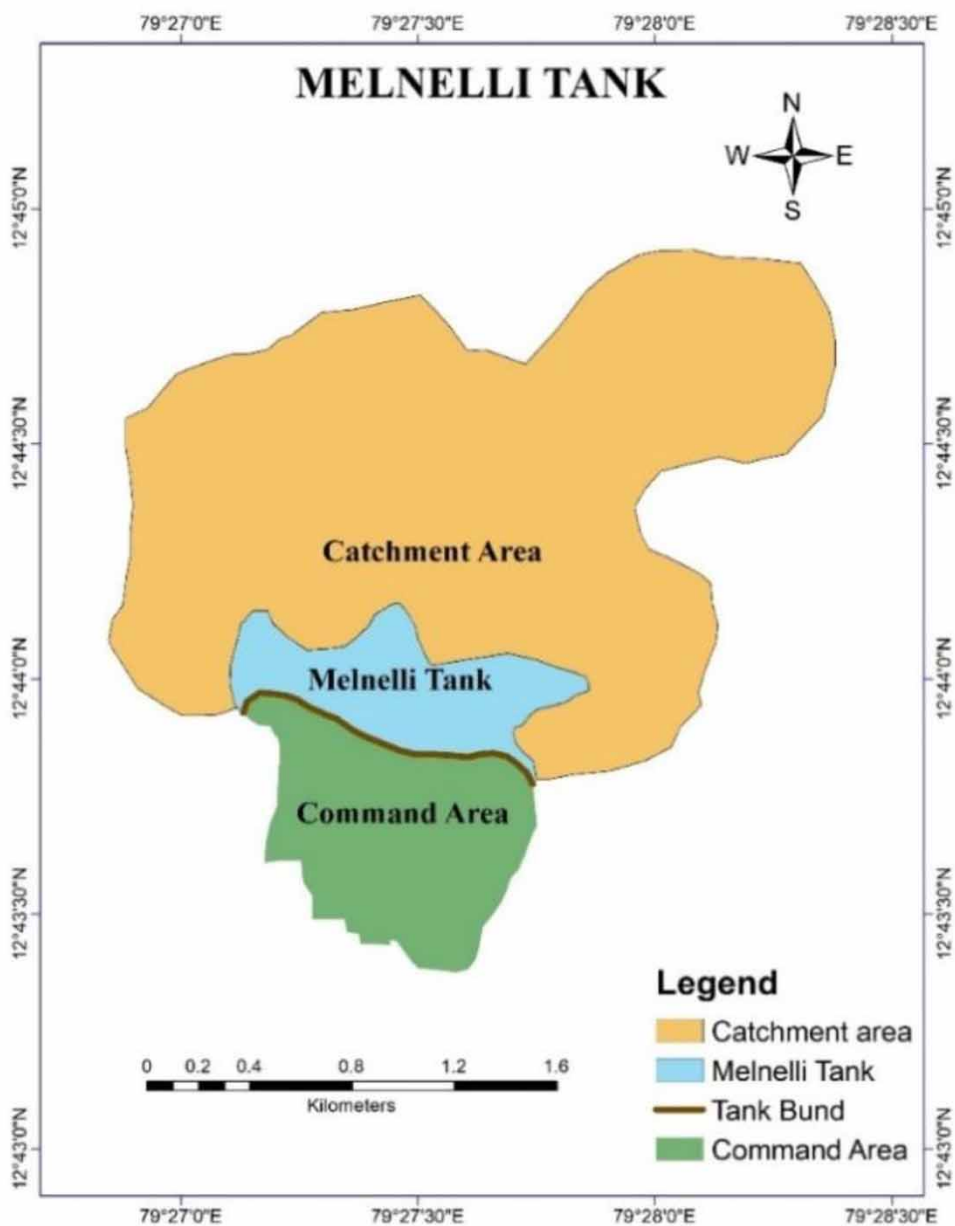

Figure 1 | Melnelli tank in Vellore district of Tamil Nadu.

is 1.28 Mm³. The reduction in capacity is mainly due to siltation in the tank bed. The FTL of the tank is +120,460 m above the mean sea level (msl) and the deepest point in the tank is +117,000 m above msl. The tank command area is 56.67 hectares.

Stage vs volume curve of the irrigation tank

Elevation data for different points in the tank bed were collected from the Public Works Department of Tamil Nadu. A contour map of 0.7 m interval was created with AutoCAD (Figure 2) using the elevation data. This map was imported into GIS environment using ArcGIS and a digital elevation model (DEM) was created. The elevation vs storage graph for the study tank was developed and plotted as shown in Figure 3. The elevation represents the water level of the tank also. By observing

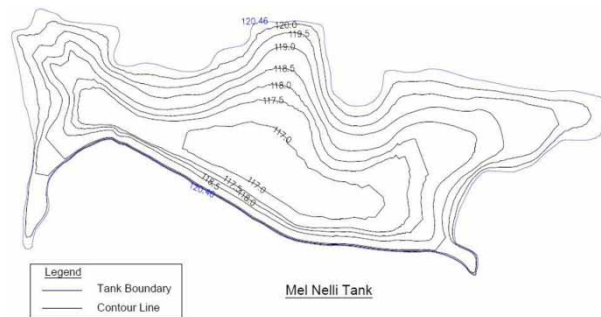

Figure 2 | Contour map of Melnelli tank in Vellore district of Tamil Nadu.

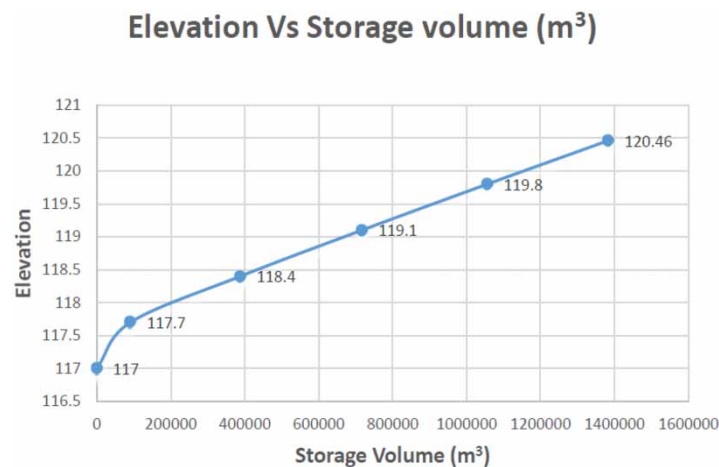

Figure 3 | Elevation vs storage volume curve of Melnelli tank.

the water level in the tank in real time, one can obtain the volume of water stored in the tank at any time using the above graph. Hence, the water resources' status of the tank can be obtained by the continuous monitoring of water level in the irrigation tank.

SENSOR CALIBRATION OF WATER LEVEL MEASUREMENT

The most widely used sensors in the field of water level monitoring are ultrasonic sensor and LIDAR sensor (Trinklein 1990; Wang *et al.* 2006). The success of this project depends upon accuracy and reliability of the data from the device. Working-wise, LIDAR and ultrasonic sensors are quite similar, but in LIDAR laser waves are used and large depths of up to 40 m can be measured. LIDAR

measurements are not affected by temperature variations but the ultrasonic sensors do vary with an increase or decrease in temperature. The one and only factor affecting the sound waves is temperature, which causes some errors in the readings. It can be rectified with the help of the following formula (Fan 2013):

$$V(m/s) = 331(m/s) + 0.6T(C) \quad (1)$$

where V is velocity in m/s, T is temperature in Celsius. Hence, by knowing the temperature, the velocity of waves is corrected. Now the corrected velocity is substituted in the following formula to find the distance between the sensor and the water level:

$$Distance(m) = (duration/1000)(ms)*(V/2)(m/s) \quad (2)$$

In this study, the ultrasonic sensor and LIDAR sensor were tested and compared for better depth measurement accuracy. The best of the two sensors is identified through calibration testing for measuring the water level. The calibration of LIDAR and ultrasonic sensors was made using an evaporation pan in the field laboratory of the Centre for Water Resources, Anna University (Figure 4). The results are compared with the actual depth of water level in the evaporation pan and are shown in Table 1.



Figure 4 | Sensors' calibration using evaporation pan.

Table 1 | Comparison of sensors

Actual depth in cm	LIDAR value	Ultrasonic sensor value	Ultrasonic sensor after temperature correction
50	47–53	49–49.5	49.8–50.3
100	97–103	98–98.5	99.7–100.3
150	147–153	147.5–148	149.7–150.3

It can be seen that the ultrasonic sensor gives greater accuracy than the LIDAR. After temperature correction, accuracy of the sensor goes up to ± 0.3 cm whereas LIDAR has an error of ± 3 cm, hence the ultrasonic sensor HR-SC04 module is chosen in this study. Ultrasonic sensor and DHT 11 module were connected with the NodeMCU controller.

METHODOLOGY AND MATERIALS

The main aim of this study is the remote monitoring of temperature, humidity and water level dynamics of the tank to estimate the volume of water available for irrigation. The conceptual flow chart explaining

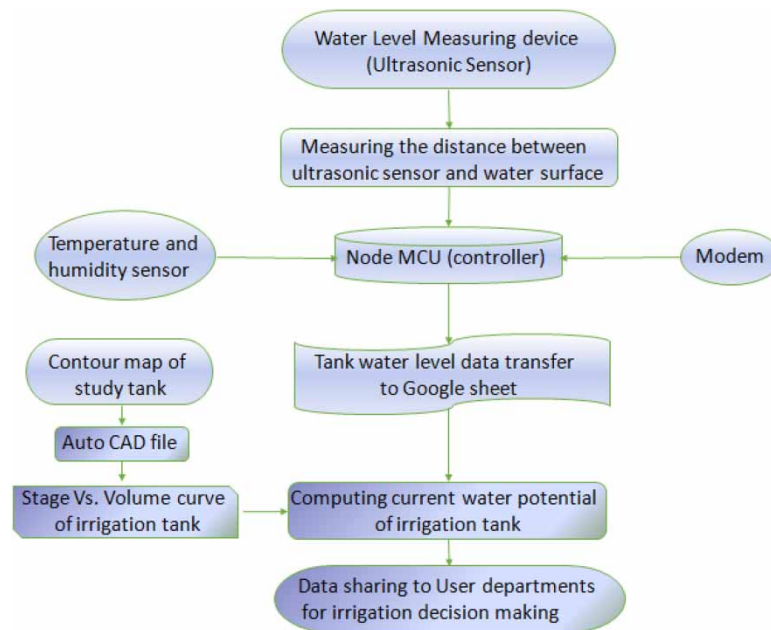

Figure 5 | Methodology for remote monitoring of tank water level dynamics.

the various processes involved in the real-time monitoring of tank water level is given in Figure 5. The IoT-based device consists of NodeMcu, sensors and power supply networks, which are explained in the following sections. NodeMcu is used to control the overall system automatically that reduces the design and control complexity. NodeMcu takes input from the sensor unit which senses the water level, temperature and humidity. The collected data from the sensor are sent to the cloud network by means of WiFi for further data analysis. The actual water level present in the tank, temperature and humidity are displayed on the Google sheets which are stored in cloud storage of Google. Anybody can use this portal to get information about the water available in the lake.

Sensor network

NodeMCU is an integrated chip which provides internet connectivity in a relatively small package based on ESP8266-12E WiFi module. It can be programmed directly through a USB port using Arduino IDE. NodeMCU can serve as the WiFi access point and station as well as the microcontroller. It consumes 5 V. The schematic representation of the sensor network is shown in Figure 6. The ultrasonic sensor and temperature-humidity sensor are connected to the digital pin of NodeMcu. A basic ultrasonic sensor consists of one or more ultrasonic transmitters, a receiver and a control module.

The ultrasonic sensor emits high frequency ultrasonic waves of about 40 KHz. These ultrasonic waves reflect back if there is a change in density of ultrasonic pulse travel medium. The reflected waves are received by the receiver in the sensor and it takes $2t$ time to receive the reflection. The depth between the sensor and water level (D) will be equal to the product of half of the duration ($t/2$) and velocity of the ultrasonic wave (v). The DHT11 temperature and humidity sensor module is a composite sensor containing a calibrated digital signal output of the temperature and humidity. This sensor can sense the relative humidity ranging from 20 to 90% with an accuracy of $\pm 5\%$ relative humidity and can sense the temperature ranging from 0 to 50 °C with an accuracy of ± 2 °C.

Power supply through solar panel

Power requirement for the total circuit is supplied by the solar panel which is made with high efficiency silicone cells. The solar cells are coated with blue nitride anti-reflection coating which

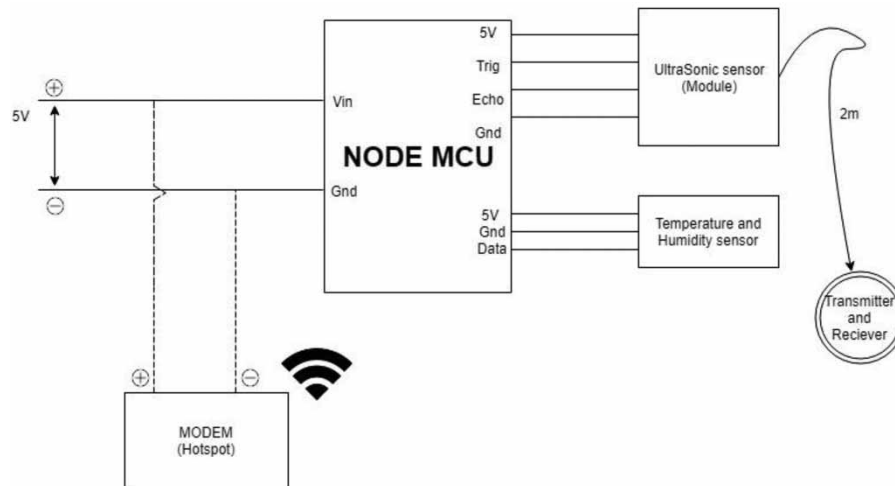

Figure 6 | Sensor network.

provides a uniform blue hue colour and increases light absorption in all weather conditions. Each panel is equipped with low-iron patterned tempered glass which provides up to 60% more strength as compared to conventional photovoltaic glass. A schematic representation of the power supply network is shown in Figure 7.

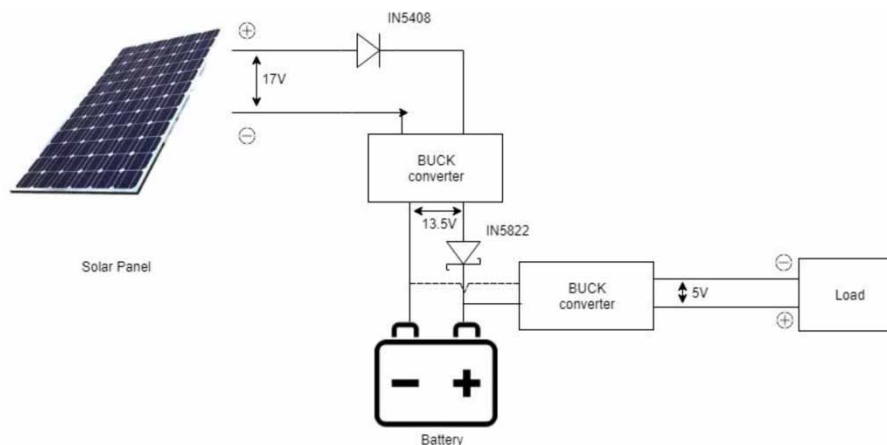

Figure 7 | Power supply.

The solar panel is capable of producing up to 17 V but the sensor network needs only 5 V DC power supply. A buck converter (step-down converter) is a DC-to-DC power converter which steps down voltage (while stepping up current) from its input (supply) to its output (load). It is a class of switched-mode power supply (SMPS) typically containing at least two semiconductors (a diode and a transistor, although modern buck converters frequently replace the diode with a second transistor used for synchronous rectification) and at least one energy storage element, a capacitor, inductor, or the two in combination. To reduce voltage ripple, filters made of capacitors (sometimes in combination with inductors) are normally added to such a converter's output (load-side filter) and input (supply-side filter). The buck converter is used when the DC output voltage needs to be lower than the DC input voltage. Efficiency of the buck converters are higher than 90%, so that it can be used to convert a main supply voltage of nearly 17–5 V DC.

Water level monitoring in irrigation tank

The IoT device is installed in the irrigation sluice which is located in the deepest level of the tank bed (+117 m above msl). The experiment was conducted during November 2017. The water level, temperature and depth are sensed and sent to the Google cloud storage through the WiFi module. The sensor provides 500 depth readings per second. A Google script program is written in Arduino IDE to record the values of depth, temperature and humidity for each second. The program performs the temperature correction on depth and pushes the corrected data to cloud storage through the built-in Wifi module of NodeMCU. Google cloud storage is utilized to store and retrieve the sensor data. A detailed program is written in Google script to retrieve the data through Google sheet and to plot the graph showing temporal variation in tank water level as shown in Figure 8. The ID indicates the time in seconds. The table shows the values of temperature, humidity and depth of water level (cm) for each second. Permission to access these data on Google sheet can be given to the concerned authorities, such as Public Works Department for decision-making. Using the stage vs volume plot, the authorities can infer the volume of water available in the tank. This device enables monitoring and studying the water level dynamics of the tank through mobile or PC remotely.

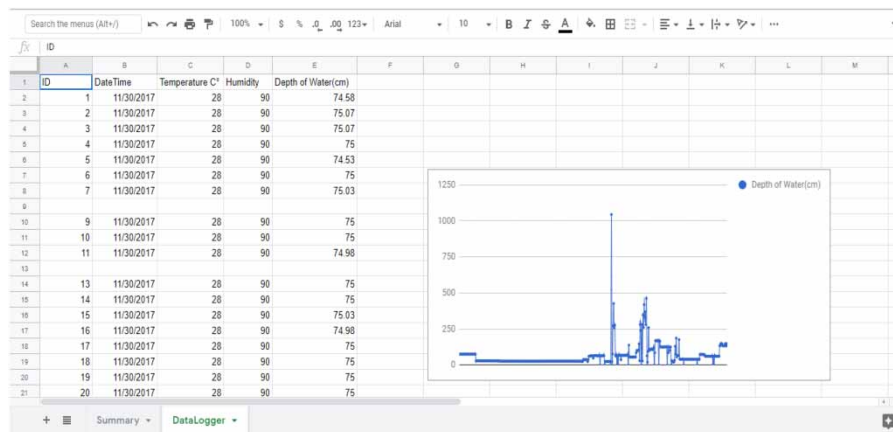

Figure 8 | Water level dynamics monitoring through web application.

CONCLUSION

IoT has been gradually bringing a sea of technological changes in our daily lives, which in turn, helps to make our lives simpler and more comfortable through various applications. A low cost, eco-friendly and simple IoT device is developed in this study for the remote monitoring of tank water level dynamics for the water administrators and the farming community who depend mainly on the tank system as their source of irrigation. This study found that the ultrasonic sensor can give accurate results when compared to that of the LIDAR sensor. The overall accuracy of the ultrasonic sensor is ± 2.5 cm. Apart from water level, the temperature and humidity are also monitored by the device. Data are available through mobile and web portals that make them very easy to access and to understand. Continuous data on water availability will be very useful for operating tank sluices, selecting crops, changing cropping pattern and other irrigation decision-making. It can also be used as a flood monitoring device which is indirectly used to warn people in the command area of the irrigation tank. The developed device can be extended to all the 39,000 tanks and 116 reservoirs of Tamil Nadu state. The IoT technologies can be applied for further areas of water resources like flood monitoring, dam seepage monitoring, overhead tanks for domestic water supply, automated evaporimeters in meteorological stations and water quality monitoring.

ACKNOWLEDGEMENT

We would like to thank the Centre for Technology Development and Transfer (CTDT), Anna University for funding this innovative project study. Our sincere thanks to Public Works Department, Palar river basin division, Vellore district for providing the necessary data.

DATA AVAILABILITY STATEMENT

Data cannot be made publicly available; readers should contact the corresponding author for details.

REFERENCES

- Anbumozhi, V., Matsumoto, K. & Yamaji, E. 2001 Towards improved performance of irrigation tanks in semi-arid regions of India: modernization. *Irrigation and Drainage Systems* **15** (4), 293–309.
- Arumugam, N., Mohan, S. & Ramaprasad, R. 2009 Sustainable development and management of tank irrigation systems in south India. *Water International* **22** (2), 90–97.
- Fan, T.-K. 2013 Smart agriculture based on cloud computing and IOT. *Journal of Convergence Information Technology* **8** (2), 210–216.
- Govindasamy, R. & Balasubramanian, R. 1990 Tank irrigation in India: problems and prospects. *International Journal of Water Resources Development* **6** (3), 211–217.
- Gunnell, Y. & Krishnamurthy, A. 2003 Past and present status of runoff harvesting systems in dryland peninsular India: a critical review. *AMBIO* **32** (4), 320–324.
- Khaled Reza, S. M., Shah Ahsanuzzaman Md, T. & Mohsin Reza, S. M. 2010 Microcontroller based automated water level sensing and controlling: Design and implementation issue. In: *Proceedings of the World Congress on Engineering and Computer Science*, October 20–22, San Francisco, CA, USA.
- Kortuem, G., Kawsar, F., Sundramoorthy, V. & Fitton, D. 2010 Smart objects as building blocks for the internet of things. *IEEE Internet Computing* **14** (1), 44–51.
- Mohammed Shahanas, K. & Bagavathi Sivakumar, P. 2016 Framework for a smart water management system in the context of smart city initiatives in India. *Procedia Computer Science* **92**, 142–147.
- Palanisami, K. 2006 Sustainable management of tank irrigation systems in India. *Journal of Developments in Sustainable Agriculture* **1**, 34–38.
- Palanisami, K. & Nanthakumaran, A. 2009 Water resources management with special reference to tank irrigation with groundwater use. In: *Second National Workshop on Strategic Issues in Indian Irrigation*, New Delhi, India, pp. 305–333.
- Patil, K. N., Tushar, K., Swaranjali, M. S. & Shreya, M. A. 2017 IOT based water level monitoring system for lake. *International Research Journal of Engineering and Technology* **4** (2), 1425–1427.
- Shanmugam, K. R. 2012 *Monitorable Indicators and Performances: Tamilnadu*, 17th edn. Madras School of Economics, Chennai, India.
- Trinklein, F. E. 1990 *Modern Physics*. Holt Rinehart and Winston, New York, USA.
- Wang, N., Zhang, N. & Wang, M. 2006 Wireless sensors in agriculture and food industry – recent development and future perspective. *Computers and Electronics in Agriculture* **50** (1), 1–14.
- Zhu, X. & Lin, Y. 2012 ZigBee implementation in intelligent agriculture based on internet of things. In: *2nd International Conference on Electronic & Mechanical Engineering and Information Technology*, Paris, France, pp. 1842–1846.

First received 28 March 2020; accepted in revised form 3 August 2020. Available online 30 September 2020